

CaFamosa

Kaffee-Espresso-Vollautomat

Fully Automatic Espresso-Maker

Macchina per espresso completamente automatica

Volautomatische koffie- en espressomachine

Täysin automaattinen espressokahviasema

Gebrauchsanweisung

Operating instructions

Istruzioni per l'uso

Gebruiksaanwijzing

Käyttöohje

1

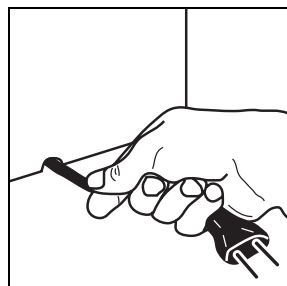
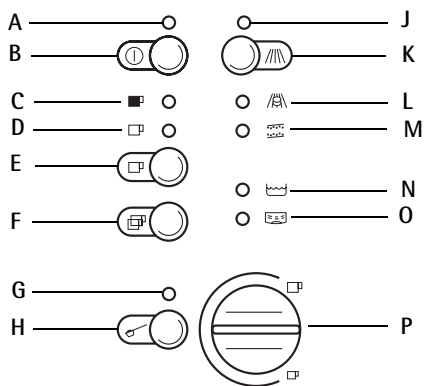
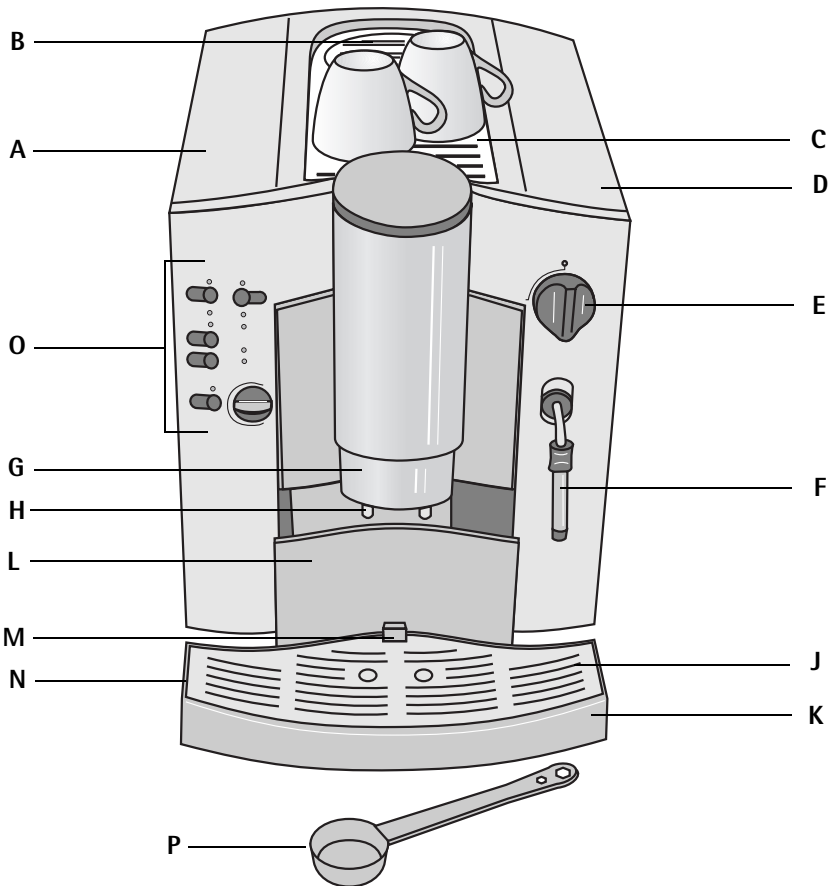

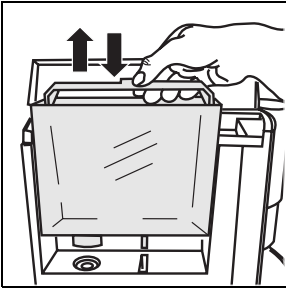

4

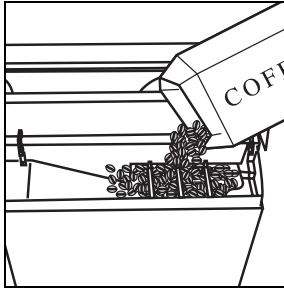

5

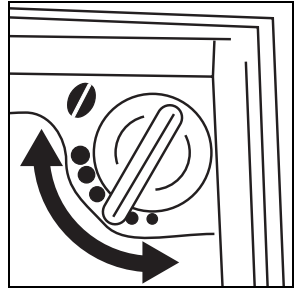

6

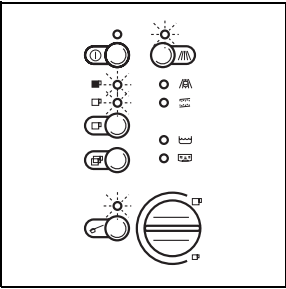

7

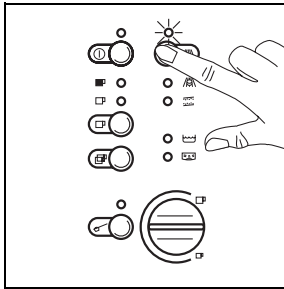

8

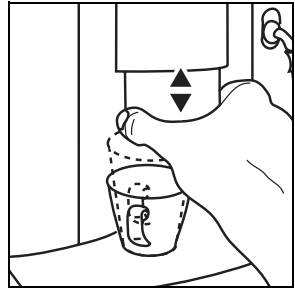

9/A

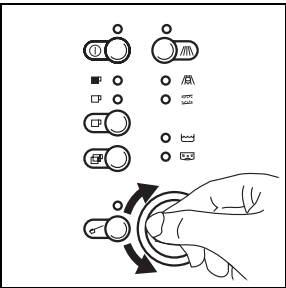

9/B

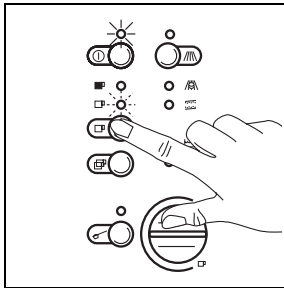

10

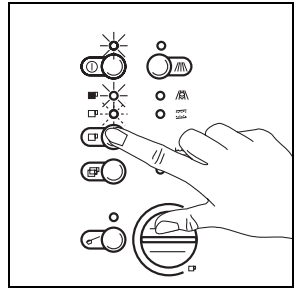

11/A

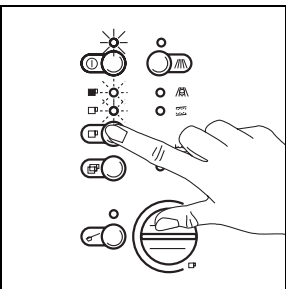

11/B

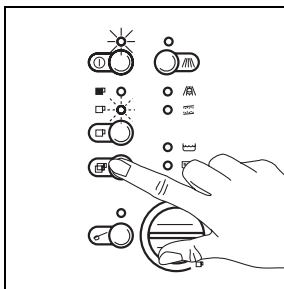

12

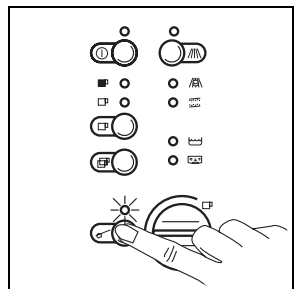

13

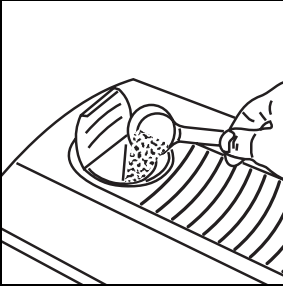

14

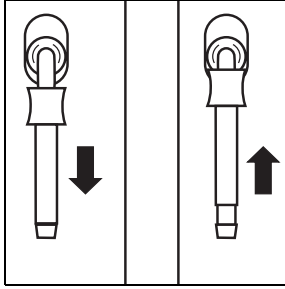

15/A

15/B

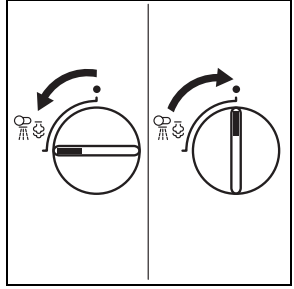

16/A

16/B

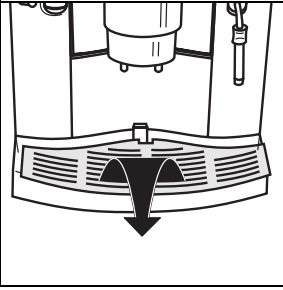

17

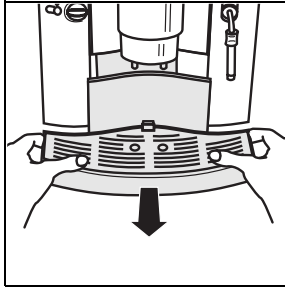

18/A

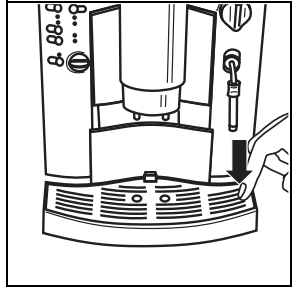

18/B

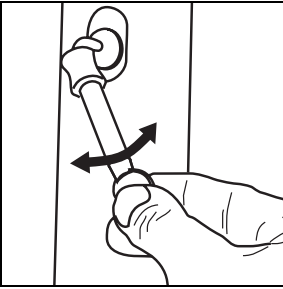

19/A

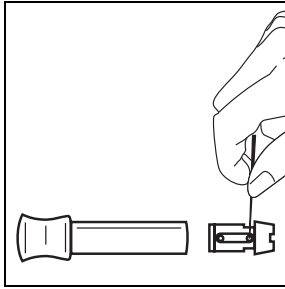

19/B

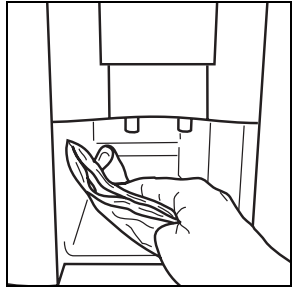

20

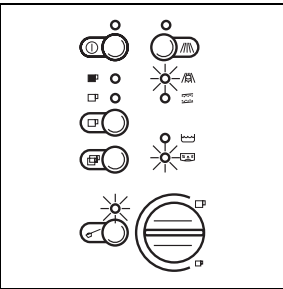

21

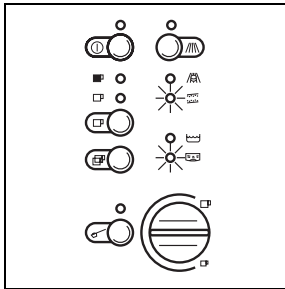

22

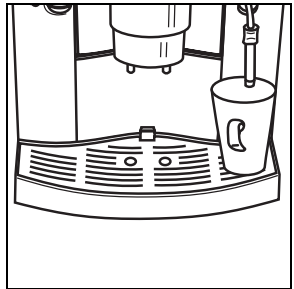

23

GB Features (Figure 1)

- A Fresh Water Tank, Lid
- B Filler Opening for Ground Coffee with Lid
- C Cup Rack
- D Bean Container with Lid (inside: grinding texture adjustment)
- E Selector Dial for Steam and Hot Water
- F Swivelling Nozzle for Steam and Hot Water
- G Height Adjustable Outlet
- H Spouts
- J Drip Grille
- K Drip Catcher
- L Spent Coffee Drawer with Spent Coffee Container
- M Float
- N Rating Plate (on the underside of the appliance)
- O Controls and Indicators (see Figure 2)
- P Measuring Spoon

Controls (Figure 2)

- A Power Indicator: Illuminates when the appliance is switched on
- B Main Switch: Switches the appliance on and off
- C Indicator For 1 Cup of Strong Coffee
- D Indicator For 1 Cup of Normal Coffee
- E Button For 1 Cup of Coffee
- F Button For 2 Cups of Coffee
- G Indicator For Ground Coffee
- H Button For Ground Coffee
- J Indicator For "Flushing"
- K Button For Flushing
- L Indicator For "Cleaning"
- M Indicator For "Descaling"
- N Indicator For "Water Tank"
- O Indicator For Emptying or Refitting The "Drip Catcher and Spent Coffee Container"
- P Selector Dial For Amount of Water per Cup

Indicator illuminates: ✱

Indicator flashes: ✱

Dear customer,

Please read these operating instructions through carefully. Above all, observe the safety instructions! Please keep these operating instructions for later reference, and pass them on to any subsequent owners of the appliance.

The form and function of your AEG coffee machine guarantee you

- straightforward **operation** and
- excellent, individual **taste**
- with the easiest of **maintenance and care**.

The excellent, individual **taste** is achieved by

- The pre-brewing system: prior to the actual brewing process, the ground coffee is moistened to extract its full aroma,
- The individually adjustable quantity of water per cup that can be varied between a small espresso and a large "frothy" coffee,
- The grinding texture that can be adjusted to suit the roasting of the beans,
- The facility to choose between normal or strong coffee,
- And last but not least, through the guaranteed crema, that small crown of froth that makes an espresso incomparable for connoisseurs.

Incidentally: The time that the water is in contact with the ground coffee is considerably shorter for espressos than for conventional filter coffee. As a result, less bitterness is released from the coffee, it is this that makes espresso coffee so much pleasanter!

Table of Contents

Safety Instructions

1. Before Using for the First Time
 - 1.1. Setting Up the Appliance
 - 1.2. Cable Compartment (Figure 3)
 - 1.3. Adjusting the Water Hardness
 - 1.4. Adjusting the Safety Cut-Out
2. Prior to Making Coffee
 - 2.1. Filling the Water Tank (Figure 4)
 - 2.2. Filling the Bean Container (Figure 5)
 - 2.3. Adjusting the Grinding Texture (Figure 6)
 - 2.4. Switching On the Appliance (Figure 7)
 - 2.5. "Flushing" the Appliance (Figure 8)
3. Making Coffee
 - 3.1. Adjusting the Amount of Water (Figure 9/B)
 - 3.2. One Cup of Normal Coffee from Beans (Figure 10)
 - 3.3. One Cup of Strong Coffee from Beans (Figure 11/A)
 - 3.4. One Cup of Extra Strong Coffee from Beans (Figure 11/B)
 - 3.5. Two Cups of Normal Coffee from Beans (Figure 12)
 - 3.6. One or Two Cups of Coffee from Ground Coffee (Figure 13, 14)
4. Frothing Milk (for Cappuccino) (Figure 15, 16)
5. Preparing Hot Water (Figure 16)
6. Switching Off the Appliance
7. Emptying the Water Tank, Drip Catcher and Spent Coffee Container (Figure 17, 18)
8. Cleaning
 - 8.1. Exterior Cleaning (Figure 19, 20)
 - 8.2. Internal Cleaning: "Clean" Indicator Illuminates (Figure 21)
9. Descaling the Appliance: "Descale" Indicator Illuminates (Figure 22, 23)
10. What to do if ...
11. Protecting the Environment
12. In the Case of Need for Service



Safety Instructions

- The appliance may only be connected to a mains supply on which the voltage, type of supply, and frequency match the information given on the rating plate (see underside of the appliance)!
- Never allow children to operate the appliance unsupervised.
- Never bring the mains lead into contact with the hot parts of the appliance.
- Never pull the plug from the socket by means of the mains lead!
- Do not use the appliance if:
 - the mains lead is damaged or
 - the housing shows visible signs of damage.
- The coffee outlet, swivelling nozzle, and cup rack will become hot during use due to the nature of their functions. Keep children away!
- Only fill the water tank with cold water, do not use hot water, milk or other liquids.
- Do not place frozen or caramelised coffee beans in the bean container, only use roasted coffee beans! Remove any foreign bodies from the coffee beans. Otherwise the guarantee will be void.
- Only put ground coffee in the ground coffee filler opening.
- Observe the cleaning and descaling instructions.
- Prior to maintaining or cleaning, switch off the appliance and unplug it from the mains!
- Never immerse the appliance in water.
- Do not allow any liquid to enter the housing via the ventilation holes on the cup rack.
- Do not wash the parts of the appliance in a dishwasher.
- Do not leave the appliance switched on longer than necessary.
- Do not expose the appliance to the weather.

Do not open or repair the appliance. Improper repairs can give rise to significant hazards for the user.

Repairs to electrical appliances are only to be performed by qualified service engineers.

In the case that repair becomes necessary, including the replacement of the mains lead, please contact

- the dealer from whom you purchased the appliance, or
- an AEG customer service centre.

In no circumstance should the appliance be sent by post - there is a risk of transport damage that cannot be covered under the guarantee!

If the appliance is used for a purpose other than that intended, or is incorrectly operated, no liability for any resulting damage or claims under the guarantee can be accepted - this is also the case if the cleaning and descaling programs are not performed immediately after the illumination of the corresponding indicators (Figure 2), and in accordance with the information given in these operating instructions.

CE This appliance complies with the following EC directives:

- 73/23/EEG dated 19.02.1973 "Low Voltage Directive", including Directive Amendment 93/68/EEG
- 89/336/EEG dated 03.05.1989 "EMC Directive", including Amendment Directive 92/31/EEG

1. Before Using for the First Time

1.1. Setting Up the Appliance

Choose a suitable, level, stable, unheated, dry surface. Pay attention to adequate air circulation.

Important: If the appliance is placed in a warm room after being brought in from the cold - wait approx. 2 hours before switching on the appliance!

1.2. Cable compartment (Figure 3)

Your appliance has a cable compartment on the rear. If the mains lead is too long, you can push the cable that is not needed into the cable compartment.





1.3. Adjusting the Water Hardness

Your appliance can be adjusted to the hardness of the water used. The correct adjustment of the water hardness is necessary for the correct function of the automatic scaling indicator (see also Section 9).



Use the Aquadur® test strips supplied to determine the hardness of the local water. Follow the instructions given on the test strip packaging. Or: Ask your water board about the hardness of your water!

The appliance has 5 hardness settings, the appliance is set to the **middle setting, 3**, in the factory (corresponds to 16°-23° degrees German hardness).

You can change this setting as follows:

-  Plug the appliance into the mains.
-  Do **not** switch on the appliance.
-  Press the  "1 Cup" button for approx. 3 seconds. The  "Descale" indicator flashes.



Pressing the  "1 Cup" button again changes the water hardness setting by one step to 4, 0, 1, 2, 3, and so on.



-  To store the water hardness setting and to end the procedure, press the  "On/Off" button. All indicators go out. If a button is not pressed for more than 30 sec., the procedure is automatically ended without changing the value saved previously.





The individual water hardness settings (degrees German hardness, ° dH) are indicated as follows:

The  "Descale" indicator **flashes** (※), in addition the following indicators **illuminate** (※)

for setting 1 (1°-7° dH):  "1 Strong Cup"

for setting 2 (8°-15° dH):  "1 Strong Cup" and  "Ground Coffee"

for setting 3 (16°-23° dH):  "1 Strong Cup",  "Ground Coffee" and  "Spent Coffee"

for setting 4 (24°-30° dH):  "1 Strong Cup",  "Ground Coffee",  "Spent Coffee" and  "Clean"

for setting 0: no further indicators illuminate. The automatic descale indicator is switched off.









Note: The water hardness setting is only to be adjusted prior to using the appliance for the first time, or if the quality of the water used changes.

1.4. Adjusting the Safety Cut-Out

If the appliance is not used for an extended period of time, it switches itself off for safety reasons and to save energy.

The appliance has 3 timer settings; after the expiry of the time set, the appliance switches off automatically. The **middle setting 2 (switch off after 2 hours)**, is set in the factory.



You can change this setting as follows:





-  Plug the appliance into the mains.
-  Do **not** switch on the appliance.
-  Press the  "2 Cups" button for approx. 3 seconds. The  "Flush" indicator illuminates.
-  Pressing the  "2 Cups" button again adjusts the timer setting by one step to 3, 1, 2 and so on.
-  To save the safety cut-out setting and end the procedure, press the  "On/Off" button. All indicators go out.

If a button is not pressed for more than 30 sec., the procedure is automatically ended without changing the value saved previously.

The individual timer settings are indicated as follows:

The  "Flush" indicator **flashes**, in addition the following indicators **illuminate**

for setting 2 (switch off after 2 hours):  "Water Tank" and  "Spent Coffee"

for setting 3 (switch off after 5 hours):  "1 Strong Cup",  "Ground Coffee",  "Clean",  "Water Tank" and  "Spent Coffee"

for setting 1: no further indicator illuminates, the automatic cut-out is not activated.

2. Prior to Making Coffee

2.1. Filling the Water Tank (Figure 4)

Open the lid (Figure 1/A) and remove the water tank by the handle. Please only use cold, clear water, and do not fill beyond the MAX mark.

Then refill the water tank in the appliance and press it down until it engages so the valve on the base is opened.

For aromatic coffee, you should:

- Change the water in the tank daily,
- Not use mineral or distilled water and
- Clean the water tank at least once a week in normal washing up water (not in a dishwasher). Then rinse with clean water.

Incidentally: When the  "Water Tank" indicator (Figure 2/N) illuminates, your appliance is signalling to you that the water tank must be refilled.

2.2. Filling the Bean Container (Figure 5)

Open the lid of the bean container (Figure 1/D) and fill the container with roasted coffee beans (do not use frozen and caramelised beans). Ensure that no foreign bodies enter the bean container. Close the lid.

Tip: You can use both espresso and filter coffee beans! Try out different sorts of beans to find the ones that taste the best to you!

2.3. Adjusting the Grinding Texture (Figure 6)

To release the full aroma from the beans, you can adjust the grinding texture to suit the roasting of the beans. The grinding texture adjustment is on the rear right inside the bean container.

Important: The grinding texture is only to be adjusted when the grinder is in operation.





Starting from the factory medium setting, turn the adjustment knob clockwise for **darker beans (coarser grinding texture)**, anticlockwise for **lighter beans (finer grinding texture)**.

Tip: Try different grinding textures to find the one that suits your taste the best!

2.4. Switching On the Appliance (Figure 7)

By pressing the  "On/Off" button (Figure 2/B) for approx. 1 second, you can switch on the appliance. The red power indicator (Figure 2/A) illuminates.

Only when using the appliance for the first time:

To show that the system must be filled, the green , ,  "Ground Coffee" and  "Flush" indicators flash (Figure 7).



 Place an empty cup under the swivelling nozzle (Figure 1/F).

 Turn the selector dial (Figure 1/E) anticlockwise to the stop.

 Hot water runs out of the swivelling nozzle and is stopped automatically.

 Turn the selector dial clockwise back to "0". Please repeat this process until the green flashing indicators go out. This process is necessary to fill the system with water.



2.5. "Flushing" the Appliance (Figure 8)



When the operating temperature is reached, the green  "Flush" indicator (Figure 2/J) illuminates. Place an empty cup under the spouts (Figure 1/H) and press the  "Flush" button (Figure 2/K). The flushing process stops automatically. The  "1 Cup of Normal Coffee" indicator (Figure 2/D) then illuminates. The appliance is now ready for brewing coffee.

Note: The water left in the appliance is removed from the the system by the flushing action so that coffee is made with fresh water.

3. Making Coffee

Although you are brewing espresso coffee with your coffee machine, the term **coffee** is used in the following for clarity.

Note: The following process starts **completely automatically** after the  "1 Cup" or  "2 Cups" button is pressed: grinding, portioning, pressing, pre-brewing, brewing, and ejection of the used ground coffee.

You can interrupt this process at any time by pressing the  "1 Cup" or  "2 Cups" button!

Store your cups upside down on the **cup rack** (Figure 1/C). Steam escapes through the openings in the cup rack, this warms the cups!

The **outlet** (Figure 1/G) can be **adjusted in height** and can thus be adjusted to suit different sizes of cup.

To adjust the height, use the thumb and index finger to grip the ribbing on the side of the outlet and move it up or down (Figure 9/A). **Important:** There is a risk of burns!

3.1. Adjusting the Amount of Water (Figure 9/B)

Using the selector dial (Figure 2/P), adjust the amount of water per cup. Depending on your taste, select a "small" espresso (turn selector dial anticlockwise) or a large "frothy" coffee (turn selector dial clockwise).

Note: You can also change the amount of water during the brewing process. To adjust the **required quantity** during the brewing process: turn the selector dial slowly anticlockwise from the maximum setting, until coffee ceases to run out at the required quantity. When **two cups** of coffee are drawn, the amount of water is more or less doubled.

Note: While the appliance is heating up, the ☐ "1 Normal Cup" indicator (Figure 2/D) flashes.

3.2. One Cup of Normal Coffee from Beans (Figure 10)

The appliance is ready for use when the ☐ "1 Normal Cup" indicator (Figure 2/D) illuminates. Place an empty cup centrally under the spouts. By **briefly** pressing the ☐ "1 Cup" button (Figure 2/E), you will obtain one cup of **normal** coffee. "1 Normal Cup" flashes.

3.3. One Cup of Strong Coffee from Beans (Figure 11/A)

The appliance is ready for use when the ☐ "1 Normal Cup" indicator (Figure 2/D) illuminates. Place an empty cup centrally under the spouts. Now press the ☐ "1 Cup" button (Figure 2/E) until the ■ "1 Strong Cup" indicator (Figure 2/C) illuminates and "1 Normal Cup" flashes. You will then obtain one cup of **strong** coffee.

3.4. One Cup of Extra Strong Coffee from Beans (Figure 11/B)

The appliance is ready for use when the "1 Normal Cup" indicator (Figure 2/D) illuminates. Place an empty cup centrally under the spouts. Now press the "1 Cup" button (Figure 2/E) until the "1 Normal Cup" and "1 Strong Cup" indicators flash. You will then obtain one cup of extra strong coffee.

3.5. Two Cups of Normal Coffee from Beans (Figure 12)

The appliance is ready for use when the ☐ "1 Cup" indicator (Figure 2/D) illuminates. Place a cup under each of the spouts.





Note: The correct position for the cups is given by the two holes in the drip grille (Figure 1/J) as these are directly below the spouts.

By pressing the ☐ "2 Cups" button (Figure 2/F), you will obtain two cups of **normal** coffee. "1 Normal Cup" flashes.

3.6. One or Two Cups of Coffee from Ground Coffee (Figure 13, 14)

Using this function you can, e.g., brew **decaffeinated** coffee.

The appliance is ready for use when the ☐ "1 Normal Cup" indicator (Figure 2/D) illuminates.

-  Place one or two cups under the spouts.
-  Press the ☞ "Ground Coffee" button (Figure 2/H) until the ☞ "Ground Coffee" indicator (Figure 2/G) illuminates (Figure 13).
-  Open the lid (Figure 1/B) and place the required amount of ground coffee for one or two cups in the filler opening (Figure 14).
-  Close the lid.

Note: Add a maximum of 2 portions of ground coffee. The filler opening for ground coffee is not a storage container. Do not add anything other than ground coffee!

- ☞ Now press the ☐ "1 Cup" button for **one cup** or the ☐ "2 Cups" button for **two cups**.

Note: If the ☞ "Ground Coffee" button is pressed inadvertently, you can cancel this setting by pressing the ☐ "1 Cup" button again. The appliance then performs a normal flush.

4. Frothing Milk (for Cappuccino) (Figure 15, 16)

Hot steam can be used both for frothing milk for cappuccino and for heating liquids.

Note: For one cup of cappuccino, fill a large cup up to 2/3 full with espresso and then add the frothed milk.

Frothing milk:

Slide the moving tube on the swivelling nozzle all the way down (Figure 15/A).

Warming liquids:

Slide the moving tube up (Figure 15/B).

- ☞ Switch on the appliance using the On/Off switch Ⓛ (Figure 2/B) and flush if necessary (see Section 2.5.). The appliance is ready for use when the ☐ "1 Normal Cup" indicator (Figure 2/D) illuminates.

- ☞ Immerse the swivelling nozzle in the container with the milk to be frothed or the liquid to be heated, and **start** the production of steam by turning the selection dial (Figure 1/E) **anticlockwise** to the stop (Figure 16/A). Due the nature of the system, a little water runs out of the swivelling nozzle first, this can be run off first, however it will not affect the quality of the result, e.g., on frothing milk.

Important: Only immerse the swivelling nozzle around half way into the liquid so that air can be drawn in unhindered. The swivelling nozzle should not touch the base of the container to avoid the hindrance of the outlet of steam. **Important:** There is a risk of burns!

- ☞ You can **stop** the outlet of steam by turning the selector dial **clockwise** to the 0-position (Figure 16/B).

In particular after frothing milk, it is recommended to briefly activate the outlet of steam to "blow out the swivelling nozzle". Then clean the any milk residues from the swivelling nozzle using a damp cloth. Move the moving metal tube up and down during this process.

After steam has been drawn off, all 4 green indicators flash to indicate that the system must be refilled with water. Proceed as follows:

- ☞ Place a container under the swivelling nozzle (Figure 1/F).
- ☞ Turn the selector dial (Figure 1/E) **anticlockwise** to the stop (Figure 16/A).
- ☞ Press the ☐ "Flush" button (Figure 2/K). Wait until the flow of water stops automatically. All 4 green indicators then flash.
- ☞ Turn the selector dial (Figure 1/E) **clockwise** back to the 0-position (Figure 16/B). The appliance is now ready for use again.

5. Preparing Hot Water (Figure 16)

You can use the hot water function for prewarming cups, for preparing instant beverages or tea. **Important:** There is a risk of burns!

- ☞ Switch on the appliance using the On/Off switch Ⓛ (Figure 2/B) and flush if necessary (see Section 2.5.). The appliance is ready for use when the ☐ "1 Normal Cup" indicator (Figure 2/D) illuminates.
- ☞ Hold a container under the swivelling nozzle and **initiate** the preparation of hot water by turning the selector dial (Figure 1/E) **anticlockwise** to the stop (Figure 16/A) **and** press the ☐ "Flush" button (Figure 2/K).
- ☞ You can **stop** the flow of hot water by turning the selector dial **clockwise** back to the 0-position (Figure 16/B).

6. Switching Off the Appliance

By pressing the On/Off switch ① (Figure 2/B), you can switch off the appliance. The power indicator (Figure 2/A) goes out.

7. Emptying the Water Tank, Drip Catcher and Spent Coffee Container (Figure 4, 17, 18)

Note: You should perform the following tasks daily!

- ✎ Remove the water tank (Figure 4) and pour away the remaining water. Use fresh water each day.
At the end of the day, however at the latest when the red float (Figure 1/M) at the rear of the drip grille becomes visible, you should empty the drip catcher and the spent coffee container. Leave the appliance switched on when performing these tasks.
- ✎ Lift the drip catcher slightly and remove it carefully from the appliance to the front (Figure 17).
- ✎ Remove the spent coffee container and empty it (Figure 18/A).
- ✎ Remove the drip grille by pressing on the left or right hand side (Figure 18/B). Pour away the water left in the drip catcher.
- ✎ Then clean the drip catcher, drip grille, as well as the spent coffee drawer and spent coffee container.

8. Cleaning

8.1. Exterior Cleaning (Figure 17, 18, 19, 20)

Water tank: Clean at least once a week in normal washing up water, not in a dishwasher. Then rinse with clean water.

Drip grille, drip catcher, and spent coffee drawer: Clean after use in normal washing up water, not in a dishwasher (Figure 17, 18).

Spent Coffee container: This part is dishwasher-safe (Figure 18/A)!

Swivelling nozzle: Wipe with a damp cloth after use. Unscrew with a coin if blocked (Figure 19/A). Remove the lower part of the nozzle and clear the frothing duct with a needle (Figure 19/B). On reassembly, ensure that the nozzle is correctly seated.

Outlet and spouts: Clean with a damp cloth as required.

Filler opening for ground coffee: Clean with a damp cloth as required. Then wipe dry.

Housing: Clean with a damp cloth as required, also the inner parts of the housing that only become accessible when the drip catcher is removed (Figure 20).

Bean container: Clean with a dry cloth from time to time.

8.2. Internal Cleaning: "Clean" Indicator Illuminates (Figure 21)

















Important: Only use original AEG cleaning tablets!



Incidentally: You can obtain original AEG cleaning tablets from AEG customer service (ET No. 663 910 480) or from your dealer (E No. 950 078 803).

Your appliance has a cleaning program for the regular cleaning of the components inside the appliance (duration approx. 15 min.); it is **not** necessary to removing the brewing unit for cleaning on this appliance.



If the  "Clean" indicator (Figure 2/L) illuminates, you should run the cleaning program as described below. Cleaning can also be carried out as described below before the indicator illuminates. You can continue to use your appliance and run the cleaning program later.

However, in this way you will endanger your rights to make a claim under the guarantee, as the unit (and thus also customer service) will detect overdue cleaning!



-  Switch the appliance on using the On/Off switch  (Figure 2/B).
-  Press the  "Flush" button (Figure 2/K) for approx. 3 seconds until the following indicators illuminate:  "Empty Spent Coffee",  "Clean" and  "Ground Coffee" (Figure 2/I).
-  Fill the water tank to the maximum mark, empty the spent coffee container and drip catcher, and refill them.
-  The  "Water Tank" (Figure 2/N) and  "Spent Coffee" indicators (Figure 2/O) go out.
-  Now place one original AEG cleaning tablet in the filler opening for ground coffee (Figure 1/B).
-  Now press the  "Ground Coffee" button (Figure 2/H), the  "Ground Coffee" indicator (Figure 2/G) goes out. The  "Clean" indicator (Figure 2/L) flashes to show that the cleaning program has started.

Note: The cleaning program can also be started by pressing the  "1 Cup" or  "2 Cups" button!

Water is now pumped through the system at short intervals to release, with the aid of the cleaning tablet, residues of coffee inside the machine.

-  If during the cleaning program the  "Spent Coffee" indicator (Figure 2/O) illuminates, empty the drip catcher and the spent coffee container, refill them and press the  "Flush" button (Figure 2/K). The cleaning program is then continued.

This action may need to be repeated up to four times.

-  The cleaning program is at an end when the  "Flush" indicator (Figure 2/J) illuminates. Flush the appliance by pressing the  "Flush" button (Figure 2/K).

-  Then empty the spent coffee container and the drip catcher, and refill them.



The appliance is now ready for use again when the  "1 Normal Cup" indicator (Figure 2/D) illuminates.

9. Descaling the Appliance (Figure 22, 23)





Your appliance has a descaling program for the regular descaling of the appliance (duration approx. 60 min.). If the  "Descal" indicator (Figure 2/M) illuminates, you should run the descaling program as described below.

Descaling can also be performed before the indicator illuminates by leaving the appliance to cool down for 2 hours and pressing the  "Flush" button (Figure 1/K) for approx. 3 seconds with the appliance switched off. You can also continue to use your appliance and run the descaling program later. **However, you will endanger your rights to make a claim under the guarantee**, as the appliance (and thus also customer service) will detect overdue cleaning!

Important: Only use liquid (**not powdered!**), environmentally friendly descaler. Only use descaler exactly as per the manufacturer's instructions. Do not use any acid-based descaler.

-  **Switch the appliance off** using the On/Off switch  (Figure 2/B) and leave it to cool down for at least 2 hours.
-  Fill the water tank with approx. 600 ml of water, only **then add the liquid descaler (never the other way round!)**

Do not switch the appliance on!

-  With the appliance switched off, press the  "Flush" button (Figure 2/K) for approx. 3 seconds until the following indicators illuminate:  "Empty Spent Coffee",  "Descal" (Figure 22).

☞ Empty the spent coffee container and the drip catcher, and refit them. The ☐ "Spent Coffee" indicator (Figure 1/O) goes out. All 4 green indicators flash, the ☐ "Descale" indicator (Figure 1/M) illuminates.

☞ Place a sufficiently large container under the swivelling nozzle (Figure 23).

☞ Start the descaling program by turning the selector dial (Figure 1/E) **anticlockwise** to the stop (Figure 16/A). The ☐ "Descale" indicator (Figure 2/M) flashes.

Descaler is now pumped through the system at short intervals.

☞ If during the cleaning program the ☐ "Spent Coffee" indicator (Figure 2/O) lights up, empty the drip catcher and then replace it. All 4 green indicators flash, the ☐ "Descale" indicator illuminates (Figure 1/M).

☞ Turn the selector dial (Figure 1/E) **clockwise** back to the 0-position (Figure 16/B). The descaling program is continued. If the ☐ "Spent Coffee" indicator (Figure 2/O) lights up, empty the drip catcher and then replace it. Do not fill the water tank until the ☐ "Water Tank" indicator (Figure 2/N) illuminates.

After a period of time, the ☐ "Flush" indicator (Figure 2/J) flashes while the ☐ "Descale" (Figure 2/M), ☐ "Water Tank" (Figure 2/N) and ☐ "Spent Coffee" indicators (Figure 2/O) illuminate.

☞ Now fill the water tank with fresh water and refit it to the appliance.

☞ Empty the drip catcher and refit. All 4 green indicators flash, the ☐ "Descale" indicator (Figure 1/M) illuminates.

☞ Place a sufficiently large container under the swivelling nozzle (Figure 23) and turn the selector dial (Figure 1/E) **anticlockwise** to the stop (Figure 16/A). The indicators ☐ "Flush" (Figure 2/J) and ☐ "Descale" (Figure 2/M) flash.

After a certain amount of time, the ☐ "Flush" indicator (Figure 2/J) flashes while the ☐ "Descale" (Figure 2/M) and ☐ "Spent Coffee" (Figure 2/O) indicators illuminate.

☞ Empty the drip catcher and refit. Turn the selector dial (Figure 1/E) **clockwise** back to the 0-position (Figure 16/B). The indicators ☐ "Flush" (Figure 2/J) and ☐ "Descale" (Figure 2/M) flash. If the ☐ "Spent Coffee" indicator (Figure 2/O) lights up, empty the drip catcher and then replace it. The descaling program is continued.

After a certain amount of time, the ☐ "Flush" indicator (Figure 2/J) flashes while the ☐ "Descale" (Figure 2/M) and ☐ "Spent Coffee" (Figure 2/O) indicators illuminate.

Empty the drip catcher and then replace it. The ☐ "Flush" indicator (Figure 2/J) illuminates.

☞ Flush the appliance by pressing the ☐ "Flush" button (Figure 2/K).

☞ Rinse out the water tank.

The appliance is now ready for use again when the ☐ "1 Normal Cup" indicator (Figure 2/D) illuminates.

10. What to do if ...

- no coffee runs out of the spouts:
 - Check that the water tank is correctly seated!
 - Fill the water tank!
 - Check the correct seating of the drip catcher!
- coffee only drips out of the spouts:
 - Set the grinding texture to a coarser setting.
- too little froth is produced on the milk during frothing?
 - Always use cool, fresh (low fat) milk!
 - Use a suitable container (e.g. jug)!
 - Also cool the container if necessary!
 - Dismantle the swivelling nozzle and clean!

- the temperature of the coffee is too low?
 - Prewarm cups with steam or hot water!
 - Caution: Sugar and milk lower the temperature of the coffee!
- coffee brewing is interrupted after grinding?
 - Fill the bean container as the brewing unit has detected that too few beans have been ground, as a result the cycle has been interrupted.
- all green indicators are flashing simultaneously?
 - See Section 4. (After drawing off steam)!
 - See Section 2.4. (Only when using the appliance for the first time).
 - Switch off the appliance. Wait 1/2 hour. Switch on the appliance, see Section 2.4. (Only when using the appliance for the first time).
 - It is possible that the filter is clogged with ground coffee. Disconnect the appliance from the mains. Pull out the spent coffee drawer. Feel inside the appliance - you will find a movable flap at the top rear of the appliance. The filter is located behind this flap. Wipe the filter clean with a dry cloth. Replace the spent coffee drawer. Finally, the system must be filled with water again. See Section 4 (After drawing off steam).
- the spent coffee container is stuck in the appliance?
 - Pull out the drip catcher together with the spent coffee drawer, carefully remove the spent coffee container from the appliance. Refit the drip catcher with the spent coffee drawer, but **without** the spent coffee container and wait until the process is complete and the ☐ "1 Cup" indicator illuminates. Then insert the drip catcher **with** the spent coffee container and spent coffee drawer!
- Indicators flash alternately?
 - Appliance is too cold. Switch off and wait approx. 1 hour before switching on the appliance again!
- the 4 green and the 4 red indicators are flashing alternately?
 - Switch off the appliance, unplug from the mains, plug into the mains again, and switch on the appliance again. If this malfunction is no longer indicated, the appliance is again ready for use.
 - If the malfunction is still present, please call customer service!
- the grinder is making loud noises?
 - Check the grinder for foreign bodies. If necessary, have the appliance checked by AEG customer service.
- the appliance is to be transported?
 - Keep the original packaging to provide protection during transport.
 - Protect the appliance from knocks.
 - In the case a **risk of frost**, drain the heater system by drawing off steam prior to transport:
 - Switch off the appliance.
 - Place a container under the swivelling nozzle.
 - Turn the selector dial (Figure 1/E) **anticlockwise** to the stop (Figure 16/A).
 - Switch on the appliance. All 4 green indicators flash.
 - Press the ☐ "Flush" button (Figure 2/K) until the only the ☐ "Flush" indicator (Figure 2/J) is still flashing. Steam comes out after a short delay.
 - Wait until the steam stops automatically.
 - Turn the selector dial (Figure 1/E) **clockwise back** to the 0-position (Figure 16/B).
 - Switch off the appliance.
 - Empty the bean container, water tank and drip catcher.

11. Protecting the Environment

Do not simply throw packaging material away.

- **Please keep** the box and the foam packaging! They can be reused in the case of the need for service to protect the appliance during transport.

If used:

- deposit plastic bags made of polythene (PE) at a collection point for recycling.
- The packing pieces made of foam polystyrene (PS) are CFC-free.

Please inquire with your local authority about your local recycling centre.

Used coffee is ideally suited to composting.

12. In the Case of Need for Service

If repairs to the appliance become necessary, including the replacement of the mains lead, please contact an AEG customer service centre **by telephone initially (in Germany please use the following hotline: 01805-306080*)**. **Under no circumstances should you send the appliance by post** - risk of transport damage that cannot be covered by the guarantee!

It is imperative that the original packing including foam parts is retained.

The guarantee is for 1 year from the date of purchase. The guarantee is restricted to 6 months if the appliance is used commercially. Commercial usage is deemed to be more than 3000 brewing cycles per year.

* = Euro 0.12/min.

AEG Kundendienst in Europa

Deutschland

Sollte dieses AEG Kleingerät wider Erwarten nicht funktionieren, wenden Sie sich bitte an unseren Service. Wir werden die Abholung und Instandsetzung durch unsere Werkstatt veranlassen.

AEG Kleingeräte-Zentralwerkstatt

Firma Trepesch GmbH

Steinstraße 500

90419 Nürnberg

In **Deutschland** stehen wir Ihnen für Fragen, Anregungen oder bei Problemen rund um unsere Kleingeräte und Raumpfleegeräte montags bis freitags von 8 bis 18 Uhr zur Verfügung.

AEG-ServiceLine: 0 18 05 – 30 60 80

(Deutsche Telekom 0,12 Euro/Min.)

Fax: 0911 – 323 49 19 30

E-Mail: service.kleingeraete@aeg-hausgeraete.de

Europa

Österreich, 4010 Linz, 0732 / 770101 – 30

Belgique/België, 1502 Lembeek, 02/363.04.44

Czech Republic, Hanusova ul., Praha 4, 02/6112 6112

Danmark, 7000 Fredericia, 70 11 74 00

España, Madrid, 1-885-2700

France, 60307 Senlis, 03-44 62 24 24

Great Britain, Service Force 08705 929 929

Hellas, 18346 ΜΟΞΑΤΟ, 01/4822646

Island, Reykjavik (Bræðurnir Ormsson hf), 91-3 88 20

Italia, 33080 Porcia (PN), 0434 39 41

Kroatien, 10000 Zagreb, 385 1 6323 333

Luxembourg, 1273 Luxembourg-Hamm, 4 24 31-443

Magyarország, 1142 Budapest, 36-1-252-1773

Niederland, 2400 AC Alphen aan den Rijn, 0172-468 300

Norge, 0516 Oslo, 22 72 58 00

Poland, 02-034 Warszawa, 022 874 33 33

Portugal, 2635-445 Rio de Mouro, (21) 926 75 75

Romania, Bucuresti, B-dul Timisoara 90, 01-444-25-81

Russia, 129090 Moscow, +7 095 956 2917, 937 7893

Slovakia, 81105 Bratislava, 07/4333 9757

Slovenija, Trazaška 132, 1000 Ljubljana, 01 24 25 730

Schweiz/Svizzera, 5506 Mägenwil, 062/889 93 00

Suomi, Porissa, puh. (02) 622 3300

Sverige, 10545 Stockholm, 08-672 53 60

Turkey, Tarlabasi cad no:35 Taksim/Istanbul-0, 262-7249420

Garantiebedingungen

Der Endabnehmer dieses Geräts (Verbraucher) hat bei einem Kauf dieses Geräts von einem Unternehmer (Händler) in Deutschland im Rahmen der Vorschriften über den Verbrauchsgüterkauf gesetzliche Rechte, die durch diese Garantie nicht eingeschränkt werden. Diese Garantie räumt dem Verbraucher also zusätzliche Rechte ein. Dies vorausgeschickt, leisten wir, AEG Hausgeräte GmbH, gegenüber dem Verbraucher **Garantie für dieses Gerät für den Zeitraum von 24 Monaten ab Übergabe** zu den folgenden Bedingungen:

1. Mit dieser Garantie haften wir dafür, dass dieses neu hergestellte Gerät im Zeitpunkt der Übergabe vom Händler an den Verbraucher die in unserer Produktbeschreibung für dieses Gerät aufgeführten Eigenschaften aufweist. Ein Mangel liegt nur dann vor, wenn der Wert oder die Gebrauchstauglichkeit dieses Geräts erheblich gemindert ist. Zeigt sich der Mangel nach Ablauf von sechs (6) Monaten ab dem Übergabezeitpunkt, so hat der Verbraucher nachzuweisen, dass das Gerät be-

reits im Übergabezeitpunkt mangelhaft war. Nicht unter diese Garantie fallen Schäden oder Mängel aus nicht vorschriftsmäßiger Handhabung sowie Nichtbeachtung der Gebrauchsanweisungen.

2. Dieses Gerät fällt nur dann unter diese Garantie, wenn es in einem der Mitgliedsstaaten der Europäischen Union gekauft wurde, es bei Auftreten des Mangels in Deutschland betrieben wird und Garantieleistungen auch in Deutschland erbracht werden können. Mängel müssen uns innerhalb von zwei (2) Monaten nach dessen Kenntnis angezeigt werden.
3. Mängel dieses Geräts werden wir innerhalb angemessener Frist nach Mitteilung des Mangels unentgeltlich beseitigen; die zu diesem Zweck erforderlichen Aufwendungen, insbesondere Arbeits- und Materialkosten werden von uns getragen. Über diese Nachbesserung hinausgehende Ansprüche werden durch diese Garantie dem Verbraucher nicht eingeräumt.
4. Im Garantiefall ist das Gerät vom Verbraucher an die für seinen Wohnort zuständige AEG-Zentral-

werkstatt zu versenden, wobei das Gerät gut zu verpacken ist und die vollständige Anschrift des Verbrauchers zusammen mit einer kurzen Fehlerbeschreibung in das Paket zu legen ist. Zum Nachweis des Garantie-Anspruchs ist der Sendung der Original-Kaufbeleg (Kassenzettel, Rechnung) beizufügen.

5. Garantieleistungen bewirken weder eine Verlängerung noch einen Neubeginn der Garantiezeit für dieses Gerät; ausgewechselte Teile gehen in unser Eigentum über.
6. Mängelansprüche aus dieser Garantie verjähren in zwei (2) Jahren ab dem Zeitpunkt der Übergabe des Geräts vom Händler an den Verbraucher, der durch den Original-Kaufbeleg (Kassenzettel, Rechnung) zu belegen ist; wenn dieses Gerät gewerblich genutzt wird, beträgt die Verjährungsfrist sechs (6) Monate.

AEG Hausgeräte GmbH
Postfach 1036
D-90327 Nürnberg

<http://www.aeg.hausgeraete.de>

© Copyright by AEG

822 949 052 - 0702