



Service Manual

MCD 36
MCD 40

Sach-Nr./Part No.
72010-748.30

Zusätzlich erforderliche Unterlagen für den Komplettservice:

Additionally required Service Manuals for the Complete Service:

Service Manual

Sicherheit
Safety

Sach-Nr./Part No.
72010-800.00

MCD 36
MCD 40

COMPACT
disc
DIGITAL AUDIO



GRUNDIG

MCD 36

(9.18335-8151 / G.HF 2800)



GRUNDIG

MCD 40

(75.1118-1051 / G.HF 2900)
(9.18337-8151 / G.HF 0400)

Es gelten die Vorschriften und Sicherheitshinweise gemäß dem Service Manual "Sicherheit", Sach-Nummer 72010-800.00, sowie zusätzlich die eventuell abweichenden, landesspezifischen Vorschriften!



The regulations and safety instructions shall be valid as provided by the "Safety" Service Manual, part number 72010-800.00, as well as the respective national deviations.

(D)

Inhaltsverzeichnis

	Seite
Allgemeiner Teil	1 - 2 ... 1 - 7
Technische Daten	1 - 2
Ausbauhinweise	1 - 3
Steuerungsablauf (Mechanik)	1 - 7
Abgleich	2 - 1
Schaltpläne und Platinenabbildungen	3 - 1 ... 3 - 12
Blockschaltplan	3 - 1
Detailschaltpläne:	
CD-Laufwerk	3 - 2
Hauptplatte Teil 1	3 - 3
Hauptplatte Teil 2	3 - 5
Platinenabbildungen	3 - 7
IC Block Diagramme	3 - 9
Explosionszeichnungen und Ersatzteilliste	4 - 1 ... 4 - 4
Ersatzteilliste MCD 36	4 - 1
Explosionszeichnung MCD 36	4 - 2
Ersatzteilliste MCD 40	4 - 3
Explosionszeichnung MCD 40	4 - 4

Allgemeiner Teil

Meßgeräte / Meßmittel

DC-Voltmeter
Test-CD Sachn-Nr. 72008-376.00

Beachten Sie bitte das GRUNDIG Meßtechnik-Programm, das Sie unter folgender Adresse erhalten:

GRUNDIG electronics GmbH
Würzburger Str. 150, D-90766 Fürth/Bay.
Tel. 0911/703-0, Telefax 0911/703-4479

Technische Daten

D/A-Wandler	1 Bit
Oversampling-Rate	8 fach
Frequenzbereich	20-20000Hz
Geräuschspannungsabstand	95dB
Gleichlaufschwankung	unter Meßgrenze
Klirrfaktor (1kHz)	0,008%
Nenn-Ausgangspegel	0,68V
Nenn-Ausgangsimpedanz	1kΩ
Stromaufnahme	400mA
Betriebstemperatur	-10°C bis +50°C
Gewicht ca.	2kg
Abmessungen (MCD 36) 25 x 6,4 x 16cm, (MCD 40) 25 x 8,1 x 16cm	

(GB)

Table of Contents

	Page
General Section	1 - 2 ... 1 - 7
Technical Data	1 - 2
Disassembly Instructions	1 - 3
Flowchart of Control Operation (Mechanics)	1 - 7
Adjustment	2 - 1
Circuit Diagrams and Layout of the PCBs	3 - 1 ... 3 - 12
Block Diagram	3 - 1
Circuit Diagrams:	
CD Drive Mechanism	3 - 2
Main Board Part 1	3 - 3
Main Board Part 2	3 - 5
Layout of the PCBs	3 - 7
IC Block Diagrams	3 - 9
Exploded Views and Spare Parts List	4 - 1 ... 4 - 4
Spare Parts List MCD 36	4 - 1
Exploded View MCD 36	4 - 2
Spare Parts List MCD 40	4 - 3
Exploded View MCD 40	4 - 4

General Section

Test Equipment / Aids

DC-Voltmeter
Test-CD Part No. 72008-376.00

Please note the Grundig Catalog "Test and Measuring Equipment" obtainable from:

GRUNDIG electronics GmbH
Würzburger Str. 150, D-90766 Fürth/Bay.
Tel. 0911/703-0, Telefax 0911/703-4479

Technical Data

D/A Converter	1Bit
Oversampling Rate	8 times
Frequency Range	20-20000Hz
Signal/Noise Ratio	95dB
Wow and Flutter	immeasurably low
Distortion Factor (1kHz)	0.008%
Nominal Output Level	0.68V
Nominal Output Impedance	1kΩ
Current Consumption	400mA
Operating Temperature	-10°C bis +50°C
Weigh approx.	2kg
Dimensions ... (MCD 36) 25 x 6.4 x 16cm, (MCD 40) 25 x 8.1 x 16cm	

Ausbauhinweise

1. Ausbau des Gehäuses (MCD 36) Fig. 1

1a. Gehäuseoberteil abnehmen

- 9 Schrauben (A) herausdrehen.
- 4 Rastnasen (1)a ausrasten und Frontblende (1) nach vorne abziehen.
- Gehäuseoberteil an der rechten Seite ausrasten, nach links hochklappen und abnehmen.

1b. Anschlußplatte ausbauen

- 2 Schrauben (B) herausdrehen.
- Anschlußplatte (C) abnehmen und Steckverbindung (D) lösen.

1c. Gehäuseunterteil abnehmen

- 4 Klebestreifen (8) abziehen und 4 Dämpfer (7) nach außen herausziehen.
- Feder (5) und Feder (6) aushängen.
- Gehäuseunterteil abnehmen.

1d. Hebel (4) ausbauen

- 2 Schrauben (E) herausdrehen.
- Die Hebel (4) bis zur Aussparung drehen und nach außen herausnehmen.

1. Ausbau des Gehäuses (MCD 40) Fig. 1a

1a. Gehäuseoberteil abnehmen

- 6 Schrauben (A) herausdrehen.
- Frontblende (1) ausrasten (8 Rastnasen (1)a) und nach vorne abziehen.
- Gehäuseoberteil an der rechten Seite ausrasten, nach links hochklappen und abnehmen.

1b. Gehäuseunterteil abnehmen

- 2 Schrauben (B) herausdrehen und Anschlußplatte (C) abnehmen.
- 4 Klebestreifen (8) abziehen und 4 Dämpfer (7) nach außen herausziehen.
- 2 Federn (5) und 2 Federn (6) aushängen.
- Gehäuseunterteil abnehmen.

MCD 36

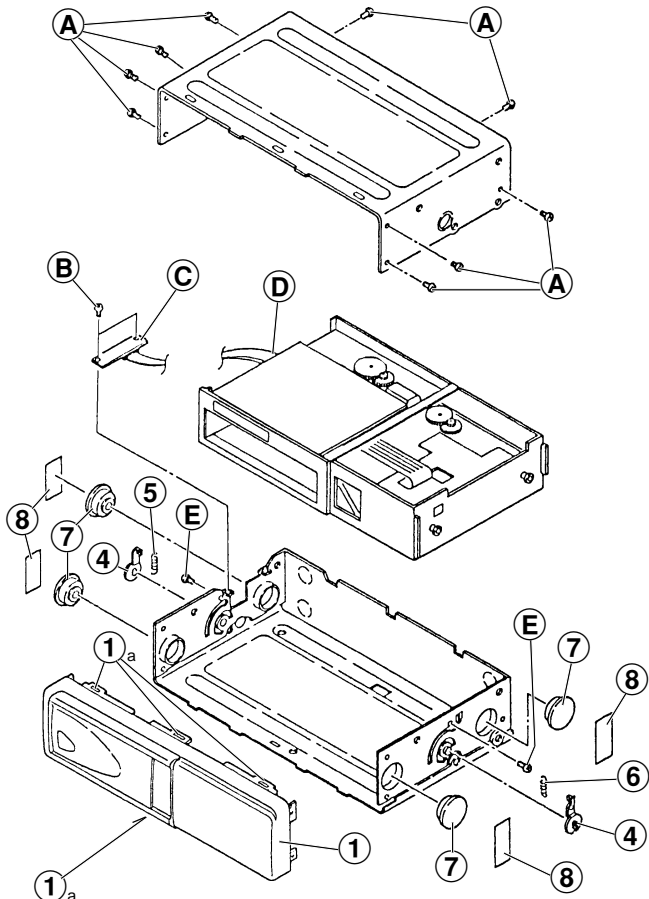

Fig. 1

Disassembly Instructions

1. Disassembling the Cabinet (MCD 36) Fig. 1

1a. Removing the Upper Part of the Cabinet

- Undo 9 screws (A).
- Disengage 4 catches (1)a and pull the front panel (1) towards the front.
- Detach the top of the cabinet on the right side and raise it towards the left to remove it.

1b. Removing the Connection PCB

- Undo 2 screws (B).
- Remove the connection PCB (C) and unplug the connector (D).

1c. Removing the Bottom Part of the Cabinet

- Remove the 4 pieces of adhesive tape (8) and pull out the 4 dampers (7).
- Unhook the spring (5) and the spring (6).
- Remove the bottom part of the cabinet.

1d. Removing the Levers (4)

- Undo 2 screws (E).
- Turn the levers (4) to the cutout and withdraw them.

1. Disassembling the Cabinet (MCD 40) Fig. 1a

1a. Removing the Upper Part of the Cabinet

- Undo 6 screws (A).
- Disengage the front panel (1) (8 catches (1)a) and pull it towards the front.
- Detach the top of the cabinet on the right side and raise it towards the left to remove it.

1b. Removing the Bottom Part of the Cabinet

- Undo 2 screws (B) and remove the connection PCB (C).
- Remove the 4 pieces of adhesive tape (8) and pull out the 4 dampers (7).
- Unhook the 2 springs (5) and the 2 springs (6).
- Remove the bottom part of the cabinet.

MCD 40

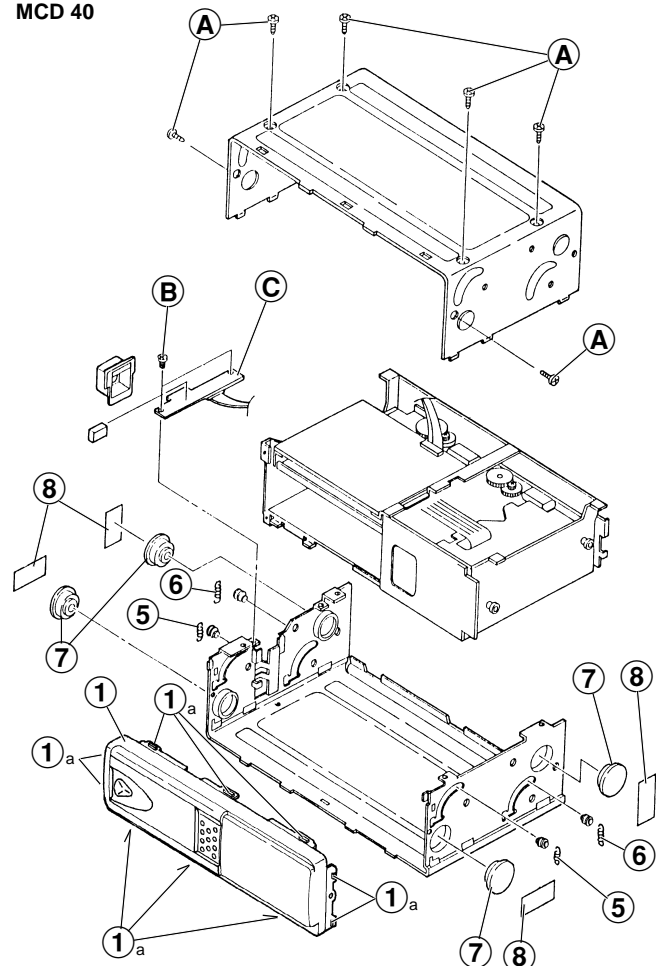

Fig. 1a

Die folgenden Ausbauhinweise beziehen sich auf das Gerät MCD 40 (für MCD 36 mit geringfügigen Abweichungen).

2. Ausbau der Hauptplatte "Main PCB"

- Gehäuseoberteil abnehmen (Pkt. 1a).
- 4 Schrauben **C11** herausdrehen (Fig. 2).
- Steckverbindungen **D**, **F**, **G** und **H** lösen (Fig. 2 und 4).
- Leiterplatte entnehmen.

3. Ausbau der Zahnräder C2, C3 und C4

- Hauptplatte "Main PCB" ausbauen (Pkt. 2).
- Schrauben **C136** (2 Schrauben bei MCD 36, 4 Schrauben bei MCD 40, Fig. 3) herausdrehen.
- Blende **C134** abnehmen.
- 4 Schrauben **C10** herausdrehen und Magazinschachtaberteil **C1** herausnehmen (Fig. 2).
- Kunststoffscheiben **C5** und **C6** (Fig. 2) abziehen.
- Zahnräder **C2**, **C3** und **C4** abziehen.

4. Ausbau des Lift-Motors C7

- Gehäuseoberteil abnehmen (Pkt. 1a).
- 2 Schrauben **C8** herausdrehen (Fig. 2).
- Lift-Motor **C7** ablöten und herausnehmen. (Beim Einbau des Motors auf die richtige Polung achten!)

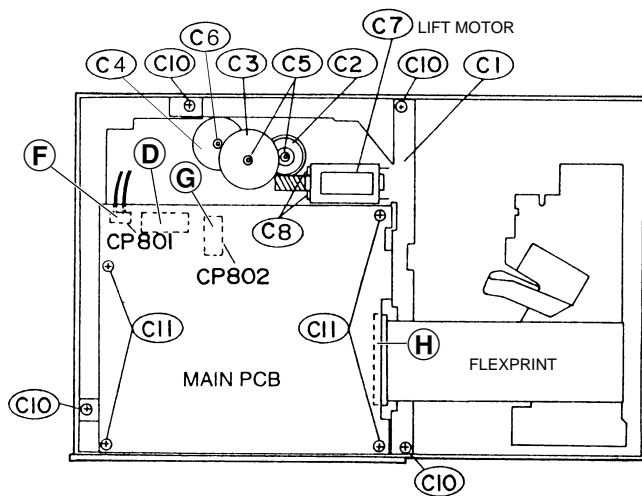

Fig. 2

5. Ausbau des Loading-Motors C48

- Gehäuseoberteil abnehmen (Pkt. 1a).
- Schrauben **C136** (2 Schrauben bei MCD 36, 4 Schrauben bei MCD 40, Fig. 3) herausdrehen.
- Blende **C134** abnehmen.
- 4 Schrauben **C10** herausdrehen und Magazinschachtaberteil **C1** herausnehmen (Fig. 2).
- Kunststoffscheiben **C53** (Fig. 5) abziehen.
- Zahnräder **C51** und **C50** abziehen.
- 2 Schrauben **C49** herausdrehen (Fig. 5).
- Loading-Motor **C48** ablöten und herausnehmen. (Beim Einbau des Motors auf die richtige Polung achten!)

6. Ausbau des Optokopplers

- Gehäuseoberteil abnehmen (Pkt. 1a).
- 2 Schrauben **I** herausdrehen (Fig. 5).
- Optokoppler **J** ablöten und herausnehmen.

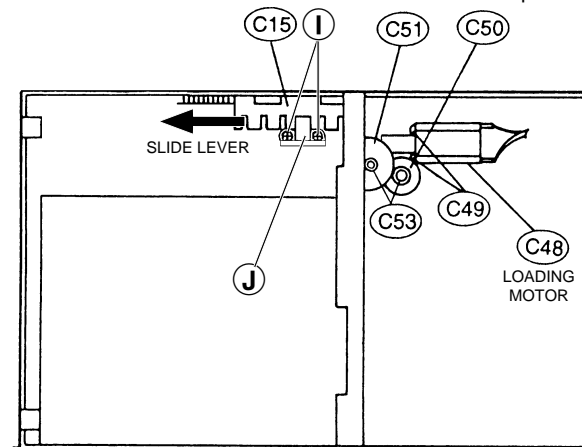

Fig. 5

The following disassembly instructions refer to the MCD 40 (and with slight differences to MCD 36).

2. Removing the "Main PCB"

- Remove the upper part of the cabinet (para 1a).
- Undo the 4 screws **C11** (Fig. 2).
- Unplug the connectors **D**, **F**, **G** and **H** (Fig. 2 and 4).
- Take out the printed circuit board.

3. Removing the Gearwheels C2, C3 and C4

- Remove the "Main PCB" (para 2).
- Undo the screws **C136** (MCD 36: 2 screws, MCD 40: 4 screws, Fig. 3).
- Remove the mechanical panel **C134**.
- Undo 4 screws **C10** and remove the cover plate of the CD magazine compartment **C1** (Fig. 2).
- Loosen and remove the plastic washers **C5** and **C6** (Fig. 2).
- Pull off the gearwheels **C2**, **C3** and **C4**.

4. Removing the Lift Motor C7

- Remove the upper part of the cabinet (para 1a).
- Undo 2 screws **C8** (Fig. 2).
- Unsolder the lift motor **C7** and take it out. (Note the correct polarity when reassembling the motor!)

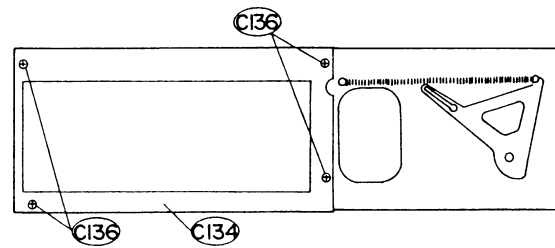

Fig. 3

Öffnen des Flexprint-Steckers
Opening the Flexprint Connector

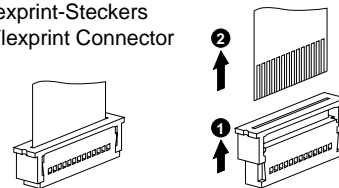

Fig. 4

5. Removing the Loading Motor C48

- Remove the upper part of the cabinet (para 1a).
- Undo the screws **C136** (MCD 36: 2 screws, MCD 40: 4 screws, Fig. 3).
- Remove the mechanical panel **C134**.
- Undo 4 screws **C10** and remove the cover plate of the CD magazine compartment **C1** (Fig. 2).
- Loosen and remove the plastic washers **C53** (Fig. 5).
- Pull off the gearwheels **C51** and **C50**.
- Undo 2 screws **C49** (Fig. 5).
- Unsolder the loading motor **C48** and take it out. (Note the correct polarity when reassembling the motor!)

6. Removing the Optocoupler

- Remove the upper part of the cabinet (para 1a).
- Undo 2 screws **I** (Fig. 5).
- Unsolder the optocoupler **J** and take it out.

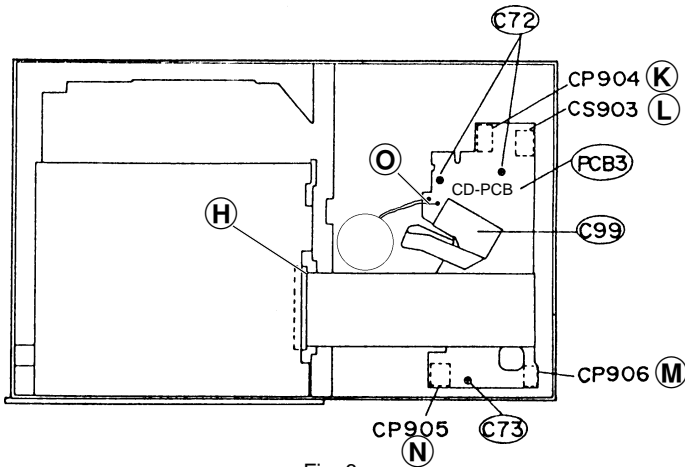

Fig. 6

7. Ausbau der Leiterplatte "CD-PCB"

- Gehäuse ausbauen (Pkt. 1)
- 2 Schrauben C72 und Schraube C73 herausdrehen (Fig. 6).
- **Wichtig: Bevor die Steckverbindungen gelöst werden, müssen die beiden Lötstellen P (Fig. 7) auf der Flexprintleitung C99 verbunden werden.**
- Steckverbindungen H, K, L, M und N lösen (Fig. 4 und 6).
- Leitungen vom Disc-Motor ablöten O.
- Leiterplatte "CD-PCB" herausnehmen.

8. Ausbau der Lasereinheit C87 (Fig. 7 und 8)

- Leiterplatte "CD-PCB" ausbauen (Pkt. 7).
- 4 Schrauben C93 herausdrehen (Fig. 8).
- Die Spurstangen C89 und C90 zusammen mit der Lasereinheit C87 vorsichtig herausnehmen.
- **Wichtig: Bevor die Steckverbindung Q der Flexprintleitung C99 gelöst wird, müssen die beiden Lötstellen R (Fig. 7) auf der Lasereinheit C87 verbunden werden.**

9. Ausbau des Disc-Motors C76 (Fig. 2, 8 und 9)

- Lasereinheit ausbauen (Pkt. 8).
- 4 Schrauben C10 herausdrehen und Magazinschachtoberteil C1 herausnehmen (Fig. 2).
- Schraube C79 herausdrehen und Schalter C78 abnehmen (Fig. 8).
- Schraube C95 herausdrehen.
- Halter C92 und Haltefeder C94 abnehmen.
- Spindel C88 herausnehmen.
- Schraube C75 herausdrehen.
- Kunststoffscheibe C86 abziehen.
- Motorhalter C74 mit Disc-Motor C76 (Fig. 9) vorsichtig herausnehmen.
- 2 Schrauben C77 (Fig. 9) herausdrehen, Motor C76 ablöten und herausnehmen. (Beim Einbau des Motors auf die richtige Polung achten!)

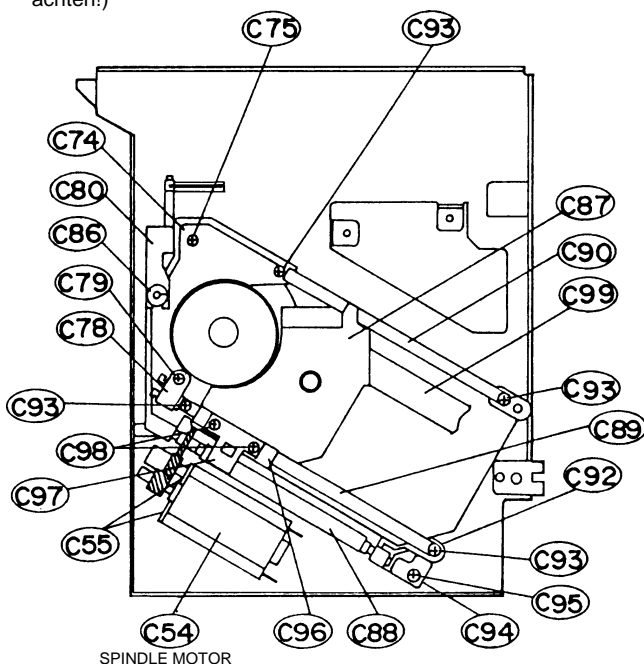

Fig. 8

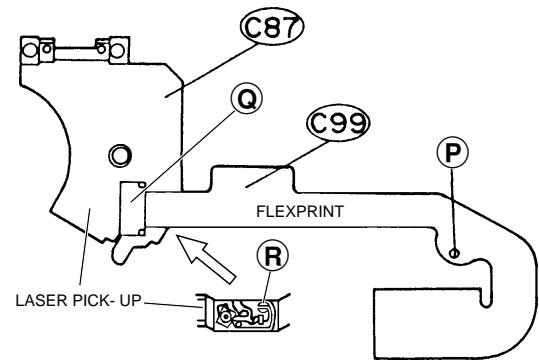

Fig. 7

7. Removing the "CD-PCB"

- Remove the cabinet (para 1)
- Undo 2 screws C72 and the screw C73 (Fig. 6).
- **Important: Before opening the connectors connect the two solder tags P on the flexprint C99 as shown in Fig. 7.**
- Disconnect the connectors H, K, L, M and N (Fig. 4 and 6).
- Unsolder the leads from the disc motor O.
- Take out the "CD-PCB".

8. Removing the Laser Pick-up C87 (Fig. 7 and 8)

- Take out the "CD-PCB" (para 7).
- Undo 4 screws C93 (Fig. 8).
- Take out the guides C89 and C90 together with the laser pick-up C87 carefully.
- **Important: Before opening the connector Q of the flexprint C99 connect the two solder tags R on the laser pick-up C87 as shown in Fig. 7.**

9. Removing the Disc Motor C76 (Fig. 2, 8 and 9)

- Remove the laser pick-up (para 8).
- Undo 4 screws C10 and remove the cover plate of the CD magazine compartment C1 (Fig. 2).
- Undo the screw C79 and take off the switch C78 (Fig. 8).
- Undo the screw C95.
- Take out the holder C92 and supporting spring C94.
- Remove the spindle C88.
- Undo the screw C75.
- Loosen and remove the plastic washer C86.
- Remove the motor holder C74 with the disc motor C76 (Fig. 9) carefully.
- Undo 2 screws C77 (Fig. 9), unsolder the motor C76 and take it out. (When re-soldering the motor note the correct polarity!).

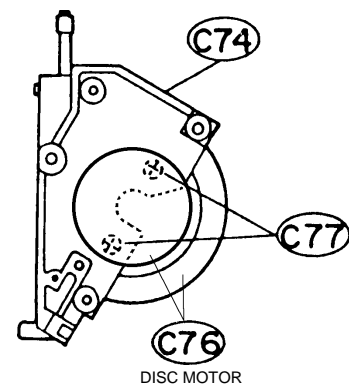

Fig. 9

10. Ausbau der Laufwerkmechanik (MCD 40)

- Gehäuse ausbauen (Pkt. 1).
- 4 Schrauben **C136** herausdrehen und Blende **C134** abnehmen (Fig. 10).
- 4 Schrauben **C10** herausdrehen und Magazinschachtoberteil **C1** mit der Leiterplatte (Main PCB) herausnehmen (Fig. 2).
- Die Laufwerkmechanik durch Bewegen des Schiebers **C15** "Slide Lever" in Pfeilrichtung (Fig. 5) nach oben fahren.
- 2 Federn **C19** und Feder **C137** aushängen (Fig. 10).
- 3 Sicherungsscheiben **C21** lösen und abnehmen (Fig. 10).
- 3 Winkel **C18** abnehmen. (Fig. 10)
- 3 Schrauben **C46** herausdrehen und vordere Halteplatte **C41** abnehmen (Fig. 10).
- Laufwerkmechanik **C47** (Fig. 10) mit den Zahnstangen herausnehmen. Achten Sie dabei auf die 3 Hülsen **C20** (Fig. 10).

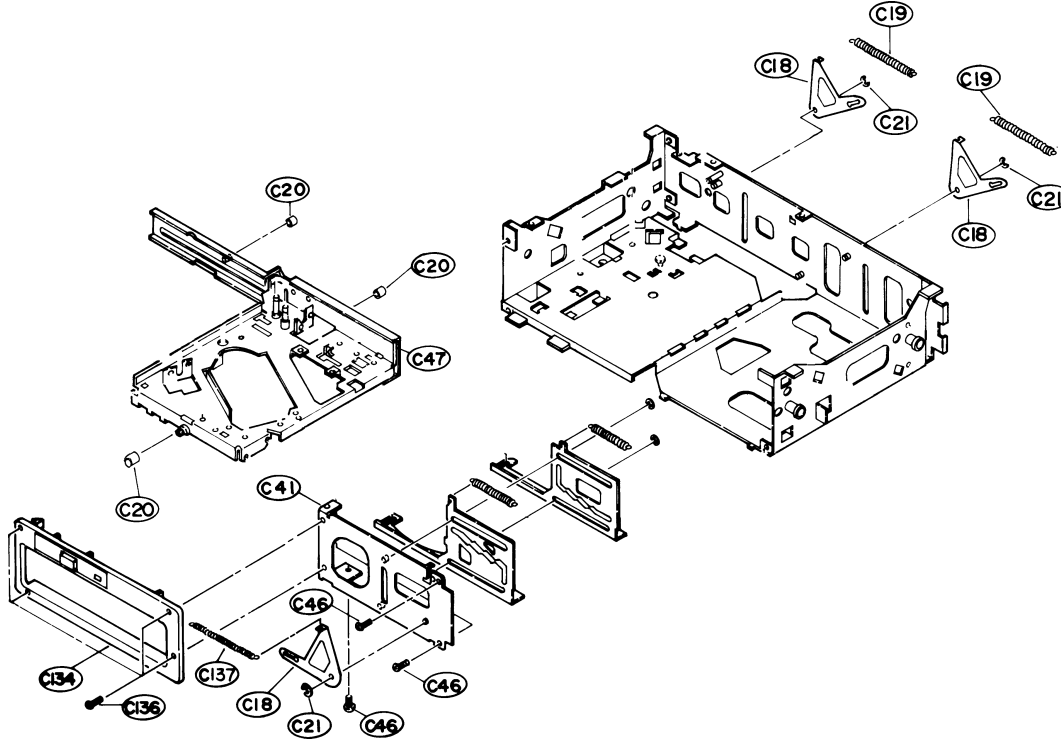

Fig. 10

10. Removing the Drive Mechanism (MCD 40)

- Remove the cabinet (para 1).
- Undo 4 screws **C136** and remove the mechanical panel **C134** (Fig. 10).
- Undo 4 screws **C10** and remove the cover plate of the CD magazine compartment **C1** with the main PCB (Fig. 2).
- Raise the drive mechanism by moving the "Slide Lever" **C15** in the direction of the arrow (Fig. 5).
- Unhook 2 springs **C19** and spring **C137** (Fig. 10).
- Loosen and remove the 3 retaining washers **C21** (Fig. 10).
- Remove the 3 brackets **C18** (Fig. 10).
- Undo 3 screws **C46** and remove the front holding plate **C41** (Fig. 10).
- Take out the drive mechanism **C47** (Fig. 10) and the toothed racks. Take care of the 3 sleeves **C20** (Fig. 10).

11. Manuelles Ausfahren der CD aus dem Laufwerk

- Das Zahnrad **C51** (Fig. 11) im Uhrzeigersinn bis zum Anschlag drehen (der Disc-Einschub wird in das Magazin geschoben).

12. Magazin mit dem Hebel "Lock Lever" auswerfen

- Nur wenn sich alle CD's im Magazin befinden, läßt es sich mit dem Hebel "Lock Lever" auswerfen.
- Hebel (Geräteunterseite) in Pfeilrichtung betätigen (Fig. 12).

13. Magazin mit dem Schieber "Slide Lever" auswerfen

- Nur wenn sich alle CD's im Magazin befinden, läßt es sich mit dem Schieber "Slide Lever" auswerfen.
- Zahnrad **C3** (Fig. 11) solange gegen den Uhrzeigersinn drehen bis sich der Schieber am Anschlag (Pfeilrichtung) befindet und das Magazin ausgeworfen wird.

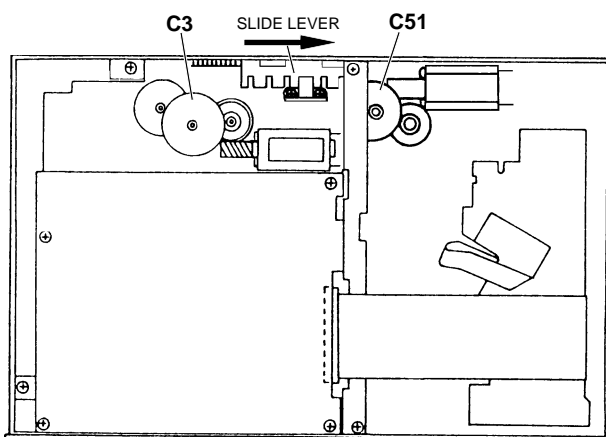

Fig. 11

11. Manual Ejection of the CD from the Drive Mechanism

- Turn the gearwheel **C51** (Fig. 11) clockwise to the limit stop (disc shelf is moved into the magazine).

12. Ejecting the Magazine with the "Lock Lever"

- Ejection with the "Lock Lever" is only possible when all CD's are in the magazine.
- Move the "Lock Lever" (bottom side) in the direction of the arrow (Fig. 12).

13. Ejecting the Magazine with the "Slide Lever"

- Ejection with the "Slide Lever" is only possible when all CD's are in the magazine.
- Turn the gearwheel **C3** (Fig. 11) anticlockwise until the "Slide Lever" arrives at the limit stop (arrow) thus ejecting the magazine.

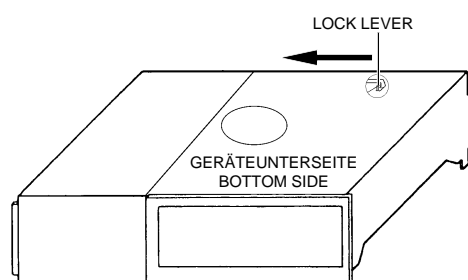
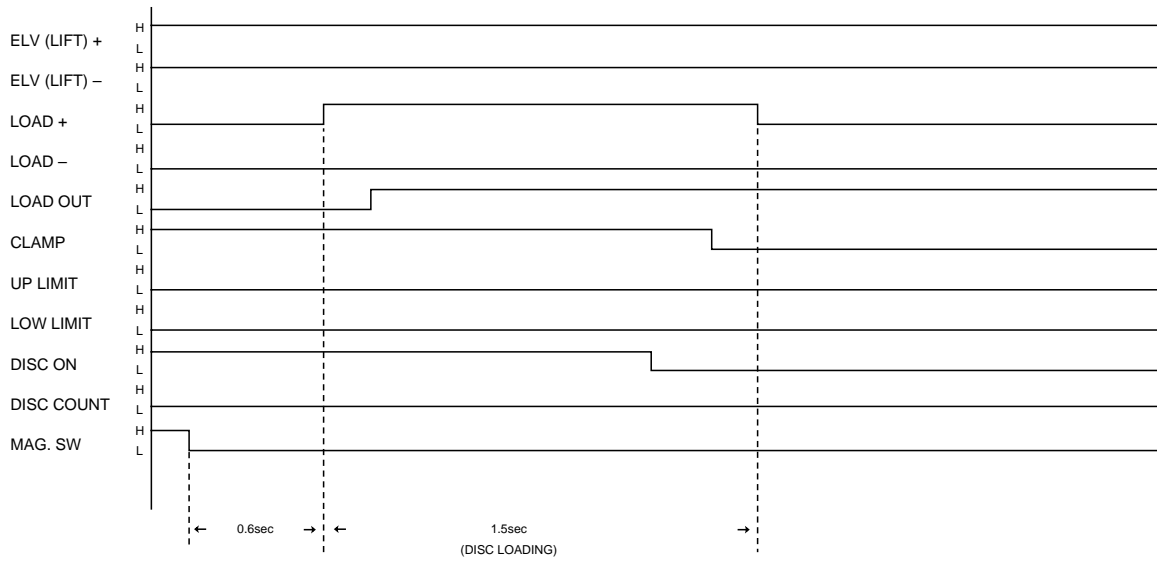

Fig. 12

Steuerungsablauf (Mechanik) Flowchart of Control Operation (Mechanics)

MAGAZINE IN



DISC CHANGE (DISC 1 → 2)

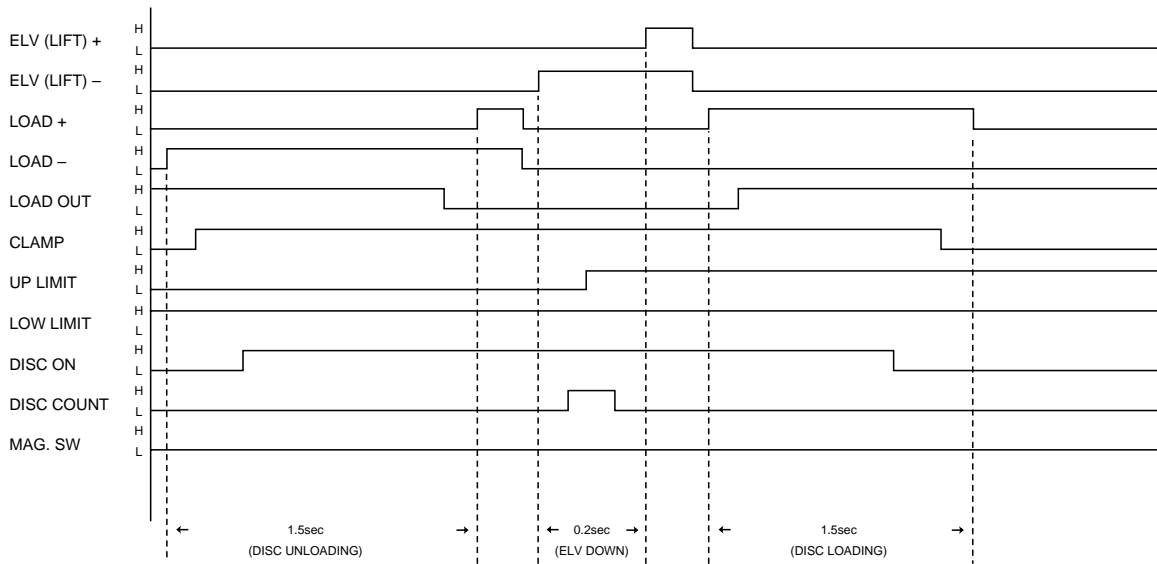

MAGAZINE EJECT (DISC 1 PLAY)

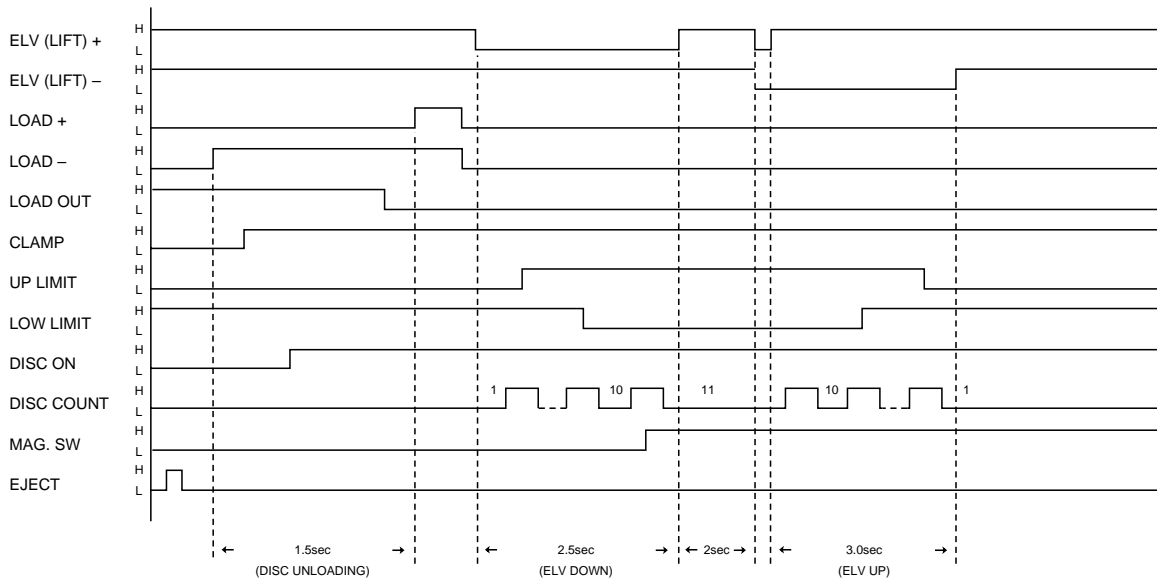

Ⓓ

Abgleich

Meßgeräte:

Autosuper, DC-Voltmeter, Test-CD (Sach-Nr. 72008-376.00).

Abgleich	Vorbereitung	Abgleichvorgang
Tracking offset	DC-Voltmeter an die Meßpunkte "VR" und "TE" anschließen (- = VR, + = TE). Test-CD einlegen. Funktion: PLAY	+10mV ± 3mV mit dem Regler SVR651 einstellen.

ⒼⒷ

Adjustment

Test equipment:

Car Radio, DC-Voltmeter, test CD (Part No. 72008-376.00)

Adjustment	Preparation	Adjustment Procedure
Tracking offset	Connect the DC-Voltmeter to the test points "VR" and "TE" (- = VR, + = TE). Load the test CD. Function: Play	Adjust +10mV ± 3mV with the adjustment control "SVR651".

DC VOLTMETER

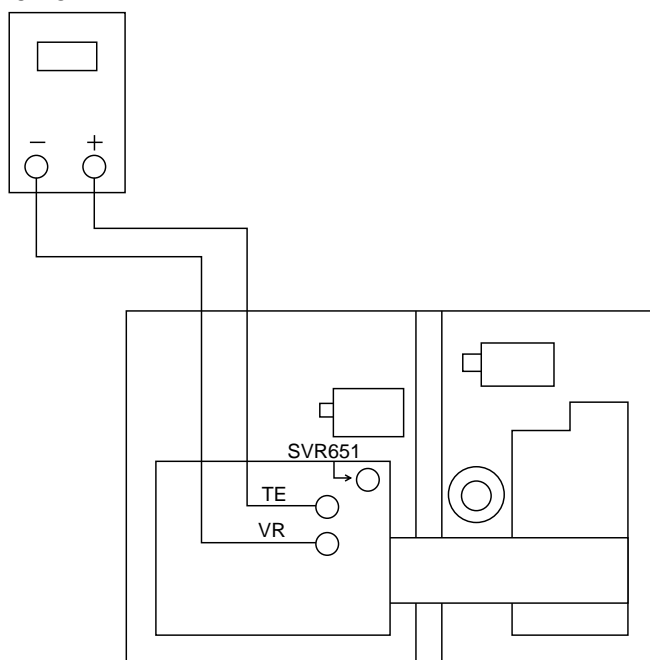

Schaltbild / Circuit Diagram (1) Hauptplatte / Main PCB

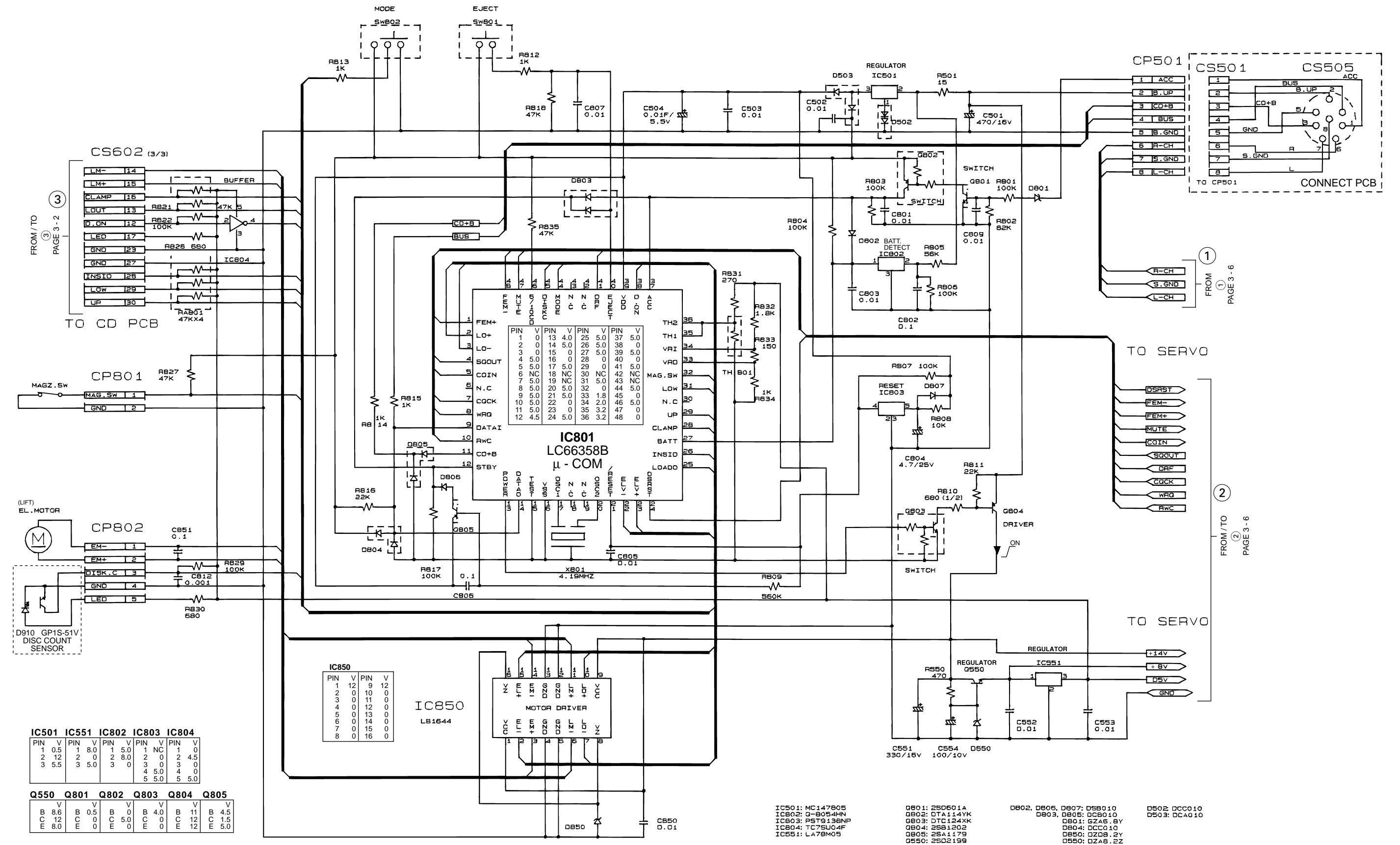

Schaltbild / Circuit Diagram (2) Hauptplatte / Main PCB

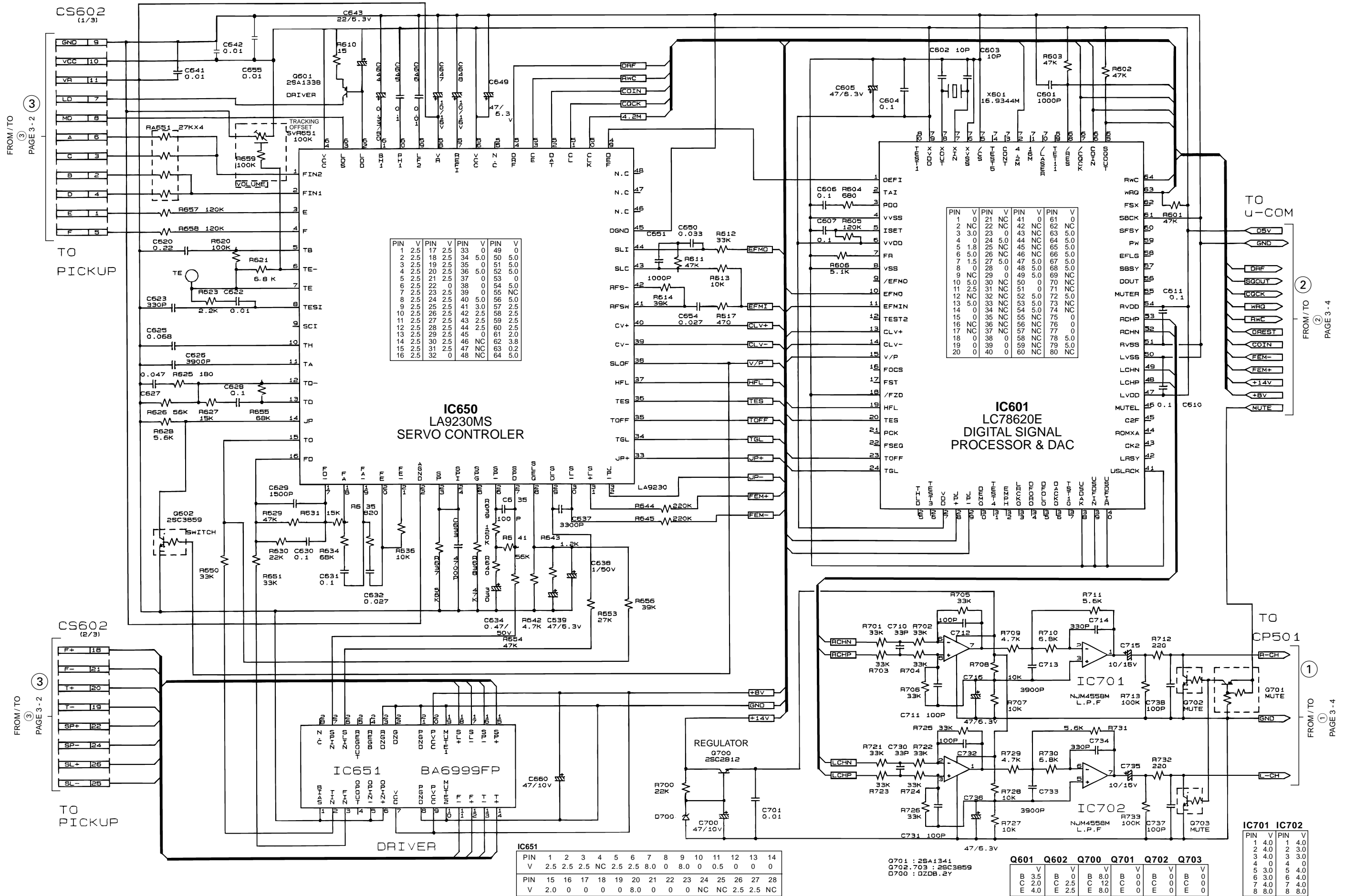



FROM/TO
PAGE 3-2

TO U-COM
PAGE 3-4

FROM/TO
PAGE 3-2

TO CP501
PAGE 3-4

Leiterplatten / PCBs

-  Bestückungsseite
Component side
-  Lötseite
Solder side

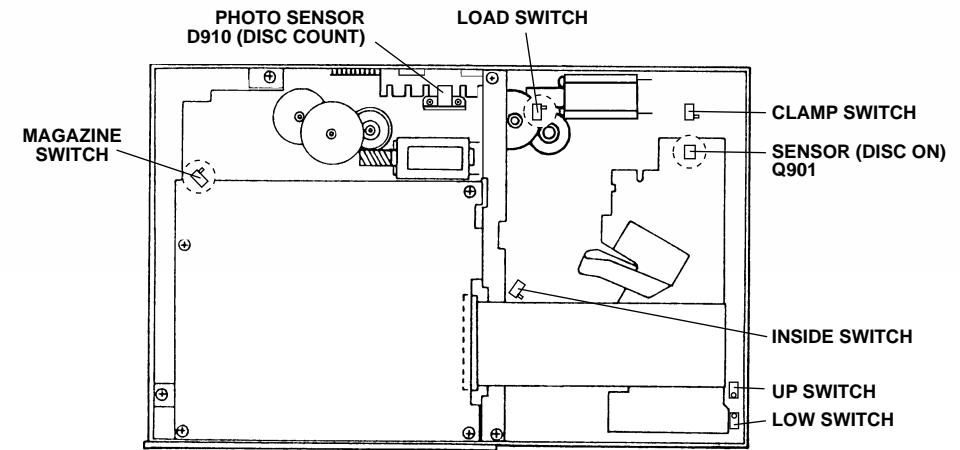
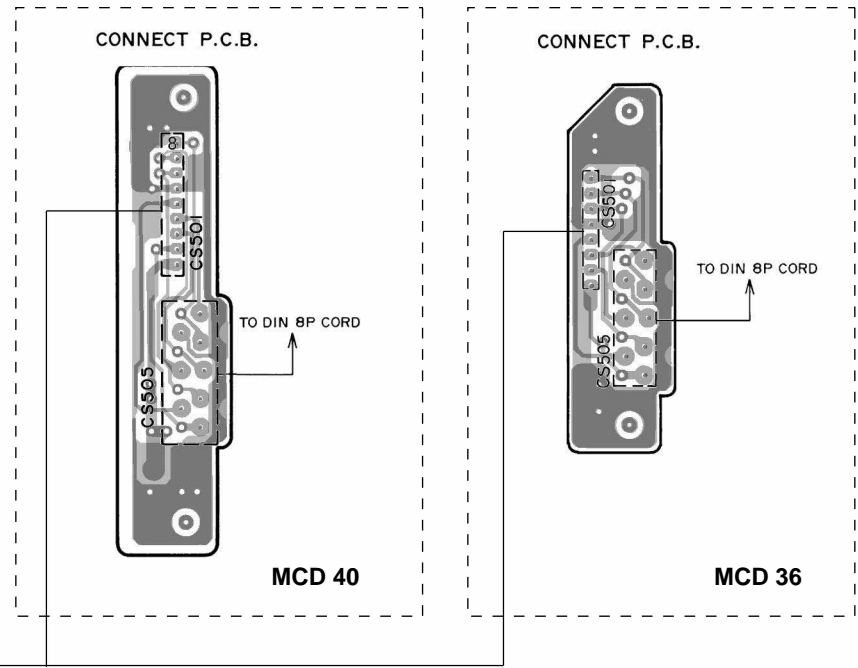
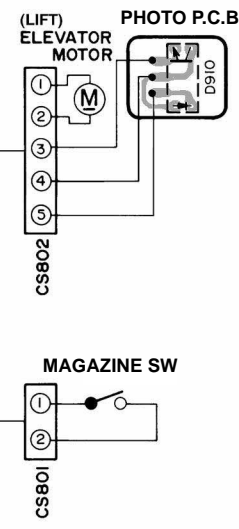
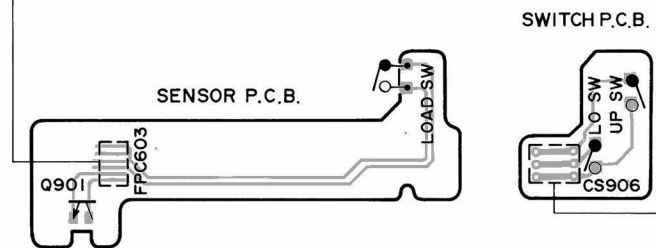
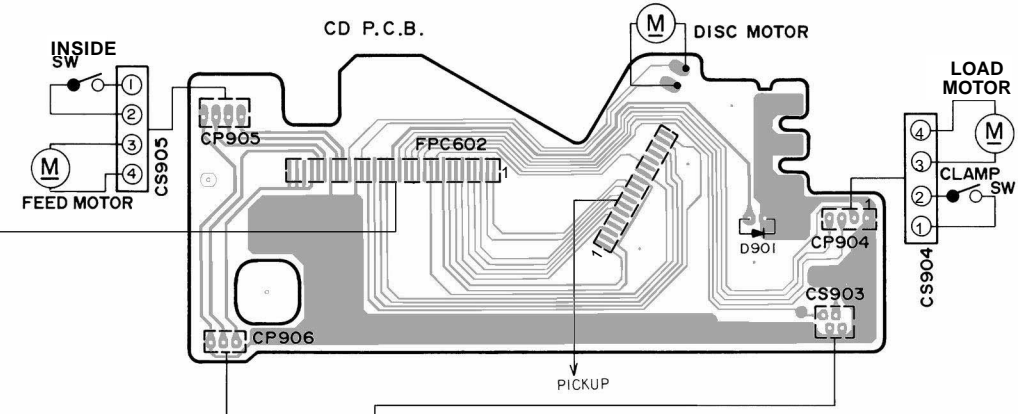
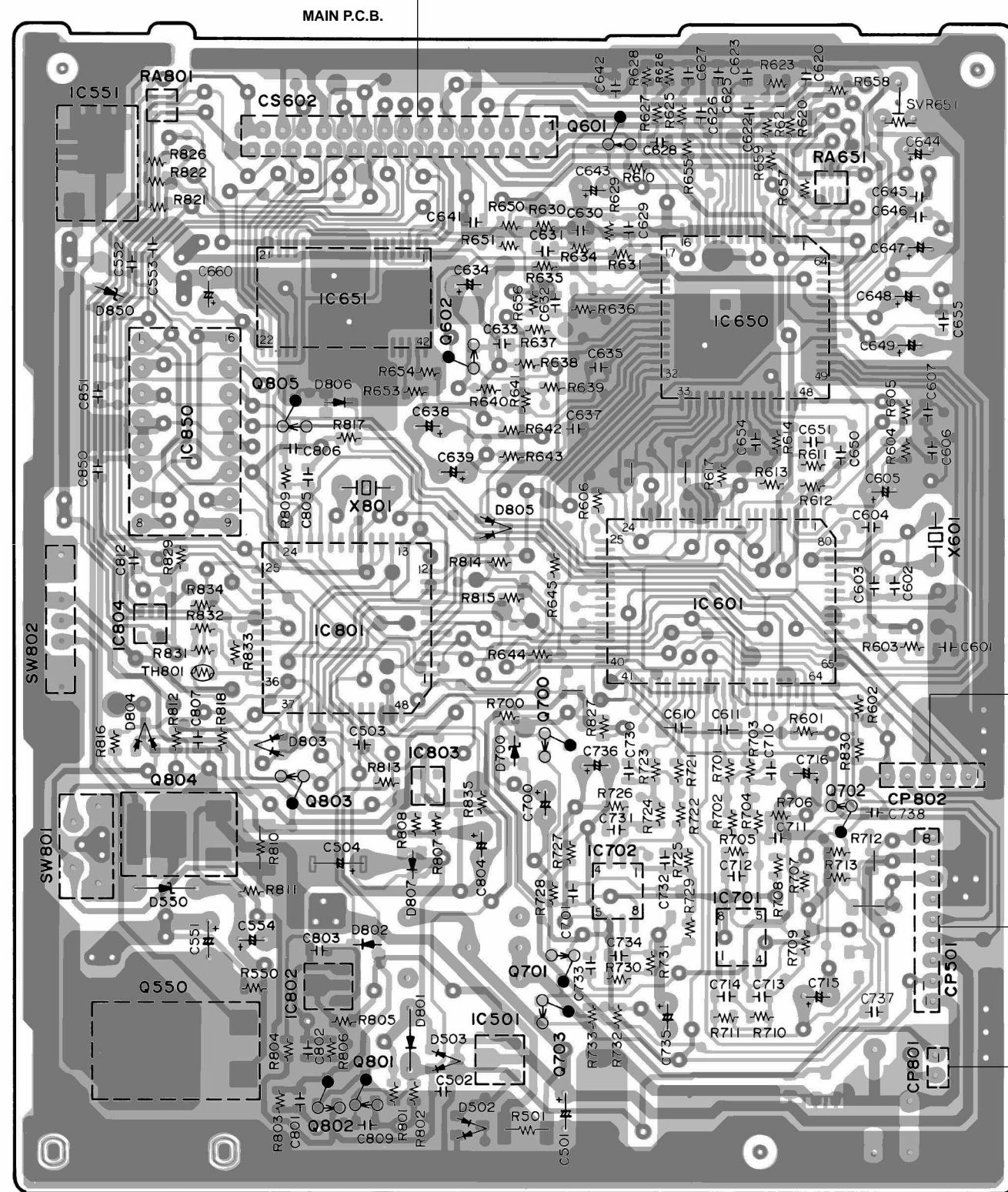

IC Blockdiagramme IC Block Diagrams

IC601 LC78620E

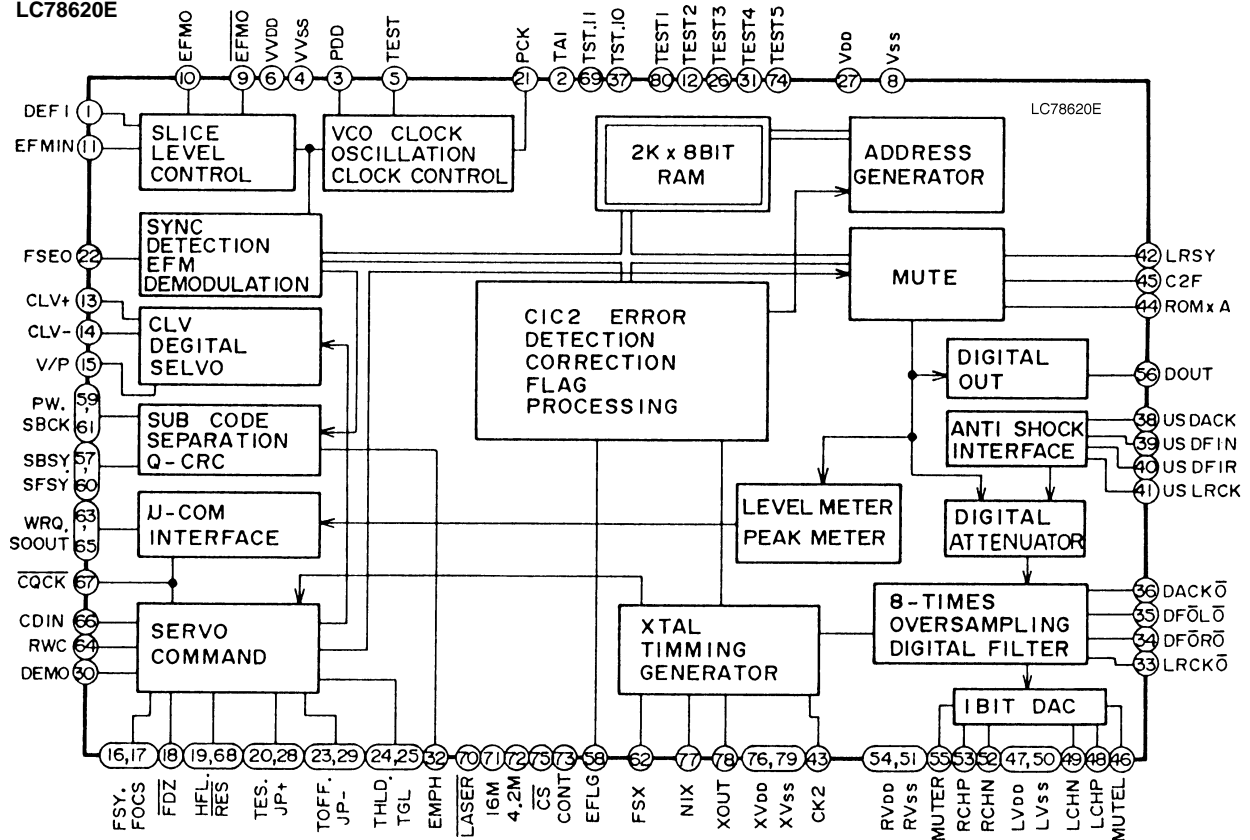

CIRCUIT OPERATION DESCRIPTION LC78620E

Terminal Number	Terminal Code	I/O	Function Explanation
1	DEFI	I	Defect detection signal (DEF) input terminal. (When unused, "L".)
2	TAI	I	For PLL
3	PDO	O	Input terminal for testing. Pulldown resistance is self-contained.
4	VVss	O	Power supply terminal for self-contained VCO. Normally 0V.
5	ISET	AI	Resistance connecting terminal for PDO output current adjustment.
6	VVDD	O	Earthing terminal for self-contained VCO. Normally 5V.
7	FR	AI	For VCO range frequency adjustment.
8	Vss	O	Earthing terminal for digital system. Normally 0V.
9	EFMO	O	For slice level control
10	EFMO	O	EFM signal reverse output terminal.
11	EFMIN	I	EFM signal output terminal.
12	TEST2	I	EFM signal input terminal.
13	CLV+	O	Input terminal for testing. Pulldown resistance is self-contained.
14	CLV-	O	Output terminal for spindle servo control. Accelerates when CLV+ is "H", slows down when CLV- "H".
15	V/P	O	Output terminal for automatic switchover monitor by rough servo / phase control. "H" causes rough servo, "L" phase control mode.
16	FOCS	O	Output terminal for focus servo on/off. "L" causes focus servo ON.
17	FST	O	Output terminal for focus start pulse. Open drain output.
18	FZD	I	Input terminal for focus error zero cross signal. (When unused, "L".)
19	HFL	I	Input terminal for track detecting signal. Schmidt input.
20	TES	I	Input terminal for tracking error signal. Schmidt input.
21	PCK	O	Clock monitoring terminal for EFM data playback. At the time of phase lock, 4.3218MHz.
22	FSEQ	O	Output terminal for synchronous signal detection. When synchronous signal detected from EFM signal and synchronous signal occurring inside correspond, "H".
23	TOFF	O	Output terminal for tracking OFF.
24	TGL	O	Output terminal for tracking gain switchover. "L" raises gain.
25	THLD	O	Output terminal for tracking hold.
26	TESTS	O	Output terminal for testing. Pulldown resistance is self-contained.
27	VDD	O	Power supply terminal for digital system. Normally 5V.
28	JP+	O	Output terminal for track jump. When JP+ is "H", accelerates at the time of outer track direction jump, or slows down at the time of inner track direction jump. When JP- is "H", accelerates at the time of inner track direction jump, or slows down at the time of outer track direction. 3 value output is possible by command.
29	JP-	O	
30	DEMO	I	Input terminal for sound turn-on function at the time of set adjustment process. Pulldown resistance is self-contained.
31	TEST4	I	Input terminal for testing. Pulldown resistance is self-contained.
32	EMPH	O	Output terminal for deemphasis monitor. At the time of "H", deemphasis disc is in playback.
33	LRCKO	O	Digital filter output.
34	DFORO	O	Word clock output.
35	DFOLO	O	RCH data output.
36	DACKO	O	LCH data output.
37	TESTIO	O	Bit clock output.
38	USDACK	I	Output terminal for testing. Open (Normally "L" output).
39	USDFIN	I	Anti-shock correspondence input. (unused, "L".)

40	USD FIR	I	Anti-shock correspondence input. (unused, "L".)	Input terminal for testing. Normally "L".
41	USLRCK	I	Word clock output. (When unused, "L".)	Word clock output. (When unused, "L".)
42	LRSY	O	ROMXA correspondence input	L/R clock output.
43	CK2	O		Bit clock output. DACLK (At the time of RES) Polarity reverse (CK2CON mode)
44	ROMAX	O		Data output. Data (Supplement) (At the time of RES) ROMOUT (ROMXA mode)
45	C2F	O		C2 Frag output.
46	MUTEL	O	For 1bit DAC	Mute output terminal.
47	LVDD	O		Power supply terminal for L channel. Normally 5V.
48	LCHP	O		L channel P output terminal.
49	LCHN	O		L channel N output terminal.
50	LVSS	O		Earthing terminal for L channel. Normally 0V.
51	RVSS	O		Earthing terminal for R channel. Normally 0V.
52	RCHN	O		R channel N output terminal.
53	RCHP	O		R channel P output terminal.
54	RVDD	O		Earthing terminal for R channel. Normally 5V.
55	MUTER	O		Mute output terminal.
56	DOUT	O		Digital OUT output terminal.
57	SBSY	O		Output terminal for synchronous signal of sub-code block.
58	EFLG	O		Terminal for monitoring C1, C2, single, double correction.
59	PW	O		Output terminal for sub-code P, Q, R, S, T, U, W.
60	SFSY	O		Output terminal for synchronous signal of sub-code frame. When sub-code is in standby, " = L".
61	SBCK	I		Input terminal for sub-code readout clock. Schmidt input.
62	FSX	O		Output terminal for 7.35KHz synchronous signal which is divided frequency from crystal oscillation.
63	WRQ	O		Output terminal for sub-code Q output standby.
64	RWC	I		Input terminal for read/write control.
65	SQOUT	O		Sub-code Q output terminal.
66	COIN	I		Input terminal for command from micro computer.
67	CQCK	I		Input terminal for command input intake clock, or sub-code offtake clock from SQOUT. Schmidt input.
68	RES	I		Chip reset input terminal. When power is supplied, changeover to "L" once.
69	TST11	O		Input terminal for testing. Open (normally "L" output).
70	LASER	O		Output terminal for laser ON/OFF. Controls by serial data command from micro computer.
71	16M	O		16.9344MHz output terminal. But outputs 33.8688MHz, only in case of quadruple speed playback mode.
72	4.2M	O		4.2336MHz output terminal.
73	CONT	O		Spare output terminal. Controls by serial data command from micro computer.
74	TEST5	I		Input terminal for testing. Pulldown resistance is self-contained.
75	CS	I		Chip select input terminal. Pulldown resistance is self-contained.
76	XVSS	O		Earthing terminal for crystal oscillation. Normally 0V.
77	Xs	I		Connecting terminal for 16.9344MHz crystal oscillator.
78	Xor	O		Connects 33.8688MHz crystal oscillator, in case of quadruple speed playback system.
79	XVDD	O		Power supply terminal for crystal oscillation. Normally 5V.
80	TEST1	I		Input terminal for testing. Pulldown resistance is self-contained.

IC650 LA9230MS

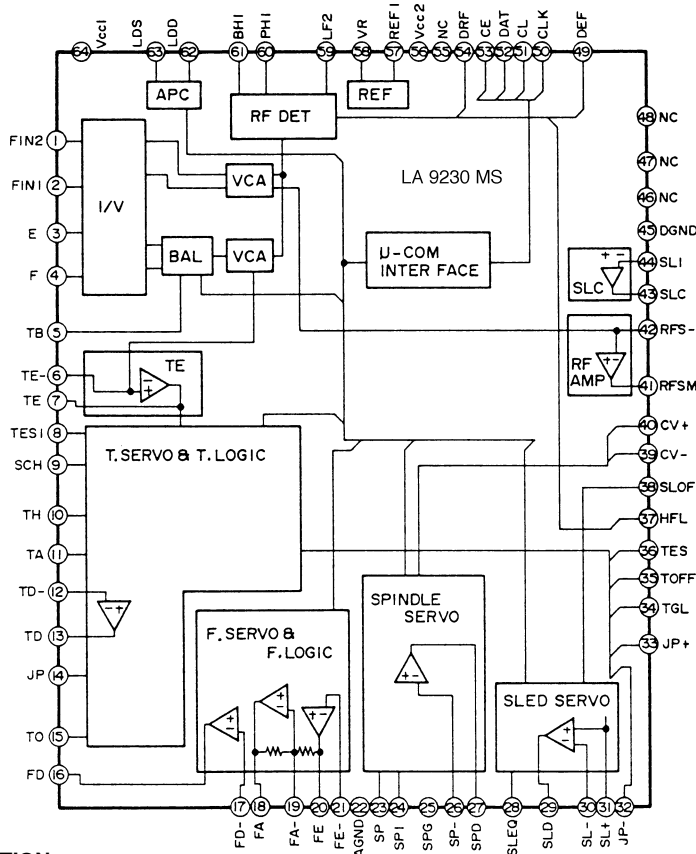
CIRCUIT OPERATION DESCRIPTION
LA9230MS

PIN No.	PART NAME	EXPLANATION
1	FIN2	Pickup photo-diode connecting pin. Forms RF signal by addition to FIN1 pin, and FE signal by subtraction.
2	FIN1	Pickup photo-diode connecting pin.
3	E	Pickup photo-diode connecting pin. Forms TE signal by subtraction from F pin.
4	F	Pickup photo-diode connecting pin.
5	TB	Pin for inputting DC constituent of TE signal.
6	TE-	Pin for connecting gain setting resistance of TE signal to TE pin.
7	TE	TE signal output pin.
8	TESI	TES (TRACK ERROR SENCE) comparator input pin. Band Pass TE signal, and input.
9	SCH	Input pin for shock detection.
10	TH	Constant setting pin at the time of tracking gain.
11	TA	Pin for connecting high pass elimination condenser of servo.
12	TD-	Pin for constituting tracking phase compensation constant between TD and VR pin.
13	TD	Pin for setting tracking phase compensation.
14	JP	Pin for setting tracking jump signal (kick pulse) amplitude.
15	TO	Tracking control signal output pin.
16	FD	Focusing control signal output pin.
17	FD-	Pin for constituting focussing phase compensation constant between FD and FA pin.
18	FA	Pin for constituting focussing phase compensation constant between FA- and FE- pin.
19	FA-	Pin for constituting focussing phase compensation constant between FA and FE pin.
20	FE	FE signal output pin.
21	FE-	Pin for connecting FE signal gain setting resistance to TE pin.
22	AGND	GND for analog signal.
23	SP	Single end output of CV+ and CV- pin input signal.
24	SPI	Spindle amplifier input.
25	SPG	Connecting pin for gain setting resistance at the time of spindle 12cm mode.
26	SP-	Connecting pin for Spindle phase compensation constant together with SPD pin.
27	SPD	Spindle control signal output pin.
28	SLEQ	Connecting pin for sled phase compensation constant.
29	SLD	Sled control signal output pin.
30	SL-	Input pin for sled delivery signal from micro computer.
31	SL+	Input pin for sled delivery signal from micro computer.
32	JP-	Input pin for tracking jump signal from DSP.
33	JO+	Input pin for tracking jump signal from DSP.
34	TGL	Input pin for tracking gain control signal from DSP. Gain low in case of TGL="H".
35	TOFF	Input pin for tracking off control signal from DSP. Off in case of TOFF="H".
36	TES	Output pin of TES signal to DSP.
37	HFL	(HIGH FREQUENCY LEVEL) is used to judge whether main beam is located above pit or above mirror.
38	SLOF	Sled servo off control input pin.
39	CV-	Input pin for CLV error signal from DSP.
40	CV+	Input pin for CLV error signal from DSP.
41	RFSM	RF output pin.
42	RFS-	Pin for setting RF gain and EFM signal 3T compensation constant together with RFSM pin.
43	SLC	(SLICE LEVEL CONTROL) is output pin for controlling data slice level by RF waveshape DSP.
44	SLI	Input pin for controlling data slice level by DSP.
45	DGND	GND pin of digital system.
46	NC	NO CONNECT.
47	NC	NO CONNECT.
48	NC	NO CONNECT.
49	DEF	Output pin for detecting disc defect.
50	CLK	Standard clock input pin. DSP4.23MHz is input.
51	CL	Micro computer command clock input pin.
52	DAT	Micro computer command data input pin.
53	CE	Micro computer command chip enable input pin.
54	DRF	(DEFECT RF) RF level detecting output.
55	NC	NO CONNECT.
56	VCC2	VCC pin for servo system and digital system.
57	REF1	Connection pin for standard voltage capacitor.
58	VR	Standard voltage output pin.
59	LF2	Pin for setting constant at the time of detecting disc defect.
60	PH1	Pin for connecting condenser for RF signal peak hold.
61	BH1	Pin for connecting condenser for RF signal bottom hold.
62	LDD	APC circuit output pin.
63	LDS	APC circuit input pin.
64	VCC1	RF system VCC pin.

IC801 LC66358B

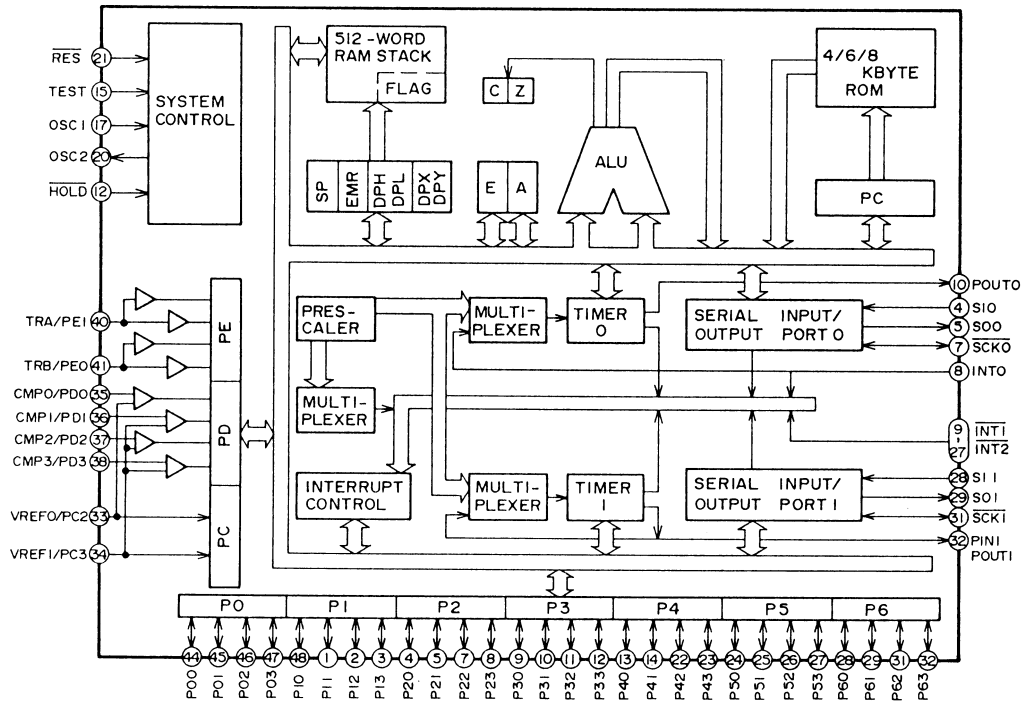

CIRCUIT OPERATION DESCRIPTION
LC66358B

PIN NO.	PORT NAME	I/O	DESCRIPTION
1	FEM+	O	Pickup moving outside output terminal
2	LO+	O	Output to move a tray in the detection out of magazine with loading motor.
3	LO-	O	Output to move a tray in the detection out of magazine with loading motor.
4	SQOUT	I	Interface with spc (LC78620E).
5	COIN	O	Interface with spc (LC78620E).
6	N.C	-	No connection
7	CQCK	O	Interface with spc (LC78620E).
8	WRQ	I	Interface with spc (LC78620E).
9	DATA I	I	Command data input.
10	RWC	O	Interface with spc (LC78620E).
11	CD+B	O	CD mode signal output terminal.
12	STBY	I	Stand by position cancellation input terminal.
13	POWER	O	Main & Servo system power supply on/off terminal.
14	DATA O	O	Status data output.
15	TEST	-	Connect to GND
16	VSS	-	Ground
17	OSC1		Cermic oscillator connection terminal for system clock.
18	N.C	-	No connection
19	N.C	-	No connection
20	OSC2		Cermic oscillator connection terminal for system clock.
21	/RESET	I	Reset signal input terminal.
22	ELV-	O	Elevator moving - down output signal.
23	ELV+	O	Elevator moving - up output signal.
24	DSRST	O	Reset signal to spc (LC78620E) output terminal.
25	LOAD O	I	Magazine tray detection SW input.
26	INSID	I	Inner circle limit detection SW input.
27	BATT	I	Battery Low detection input terminal.
28	CLAMP	I	Disc clamp finish SW input.
29	UP	I	Elevator upper limit SW input.
30	N.C	-	No connection
31	LOW	I	Elevator lower limit SW input.
32	MAG.SW	I	Magazine detection SW input.
33	VRO	I	Reference voltage for TH1.
34	VRI	I	Reference voltage for TH2.
35	TH1	I	Temperature sensor ON input signal.
36	TH2	I	Temperature sensor OFF input signal.
37	ACC	I	Acc ON/OFF detection input.
38	D.ON	I	Disc detection Photo transistor input terminal.
39	VDD	-	Power supply terminal(+5V).
40	EJECT	I	Magazine Eject key input terminal.
41	DRF	I	Detect RF signal input terminal.
42	N.C	-	No connection
43	N.C	-	No connection
44	MODE	I	Initial setting input terminal for change 1 or 2 switching.
45	DISK C	I	Elevator Position detection pulse input.
46	6/10 CD	I	Initial setting input terminal for 6 discs chngcr switching.
47	MUTE	O	Mute output terminal
48	FEM-	O	Pickup moving-inside output signal.

IC651 BA6999FB

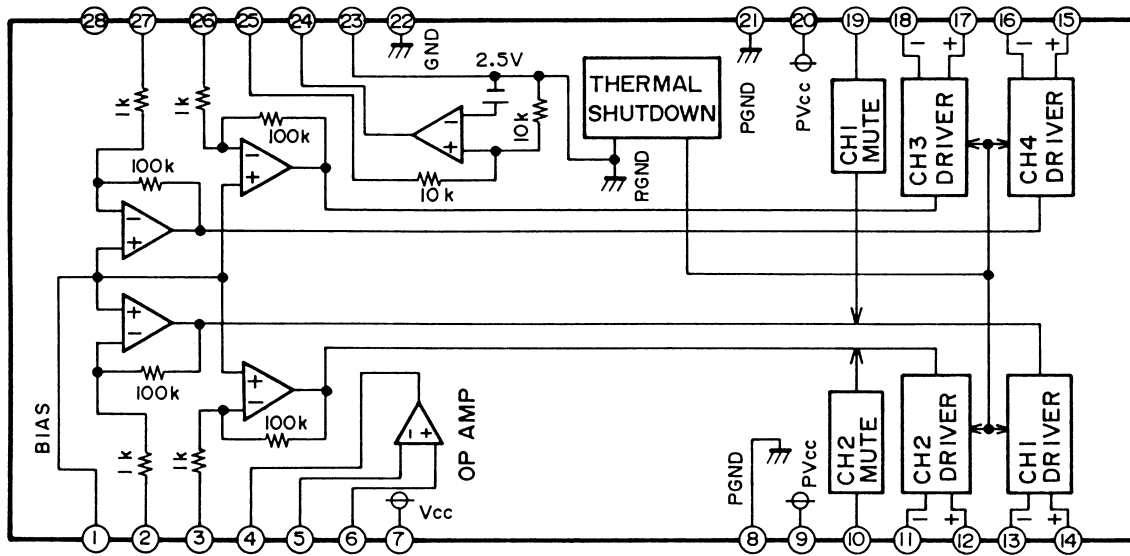

IC850 LB1644

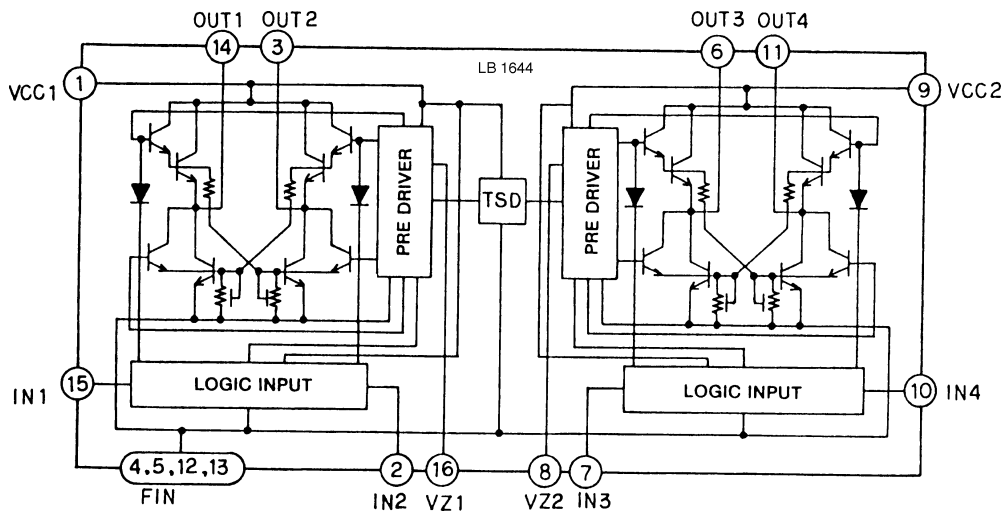

IC803 PST9138N

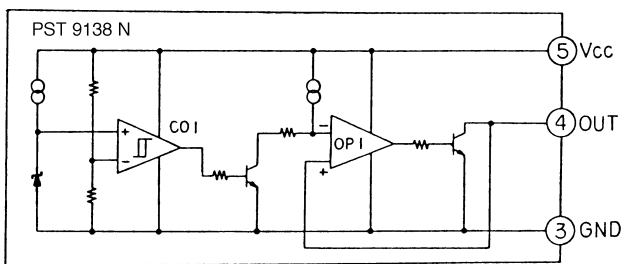

IC701/702 NJM4558M

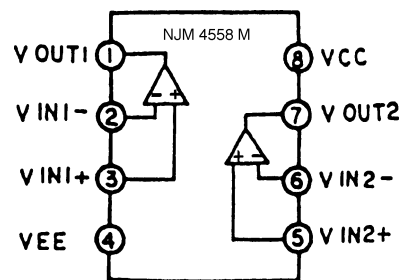

IC802 S8054HN

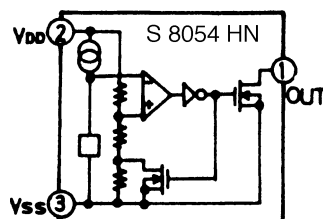

GRUNDIGErsatzteilliste
Spare Parts List

D Btx * 32700 #

12 / 95

MCD 36

SACH-NR. / PART NO.: 9.18335-8151
BESTELL-NR. / ORDER NO.: G.HF 2800

POS. NR. POS. NO.	ABB. FIG.	SACHNUMMER PART NUMBER	ANZ. QUA.	BEZEICHNUNG D	DESCRIPTION GB
72008-848.99 TAUSCHGERAET EXCHANGE SET					
A001.000	1	75954-033.29		GEHAEUSE VORDERTEIL	HOUSING
A002.000	1	75952-038.02		GEHAEUSE-OBERTEIL	CABINET TOP
A003.000	1	75954-033.31		GEHAEUSE BODEN	HOUSING
A004.000	1	75952-038.04		HEBEL	LEVER
A005.000	1	75952-038.05		FEDER, LINKS	SPRING / LEFT
A006.000	1	75952-038.06		FEDER, RECHTS	SPRING / RIGHT
A007.000	1	75952-038.07		DAEMPfung	DAMPING OR ATTENUATION
A008.000	1	75952-038.08		ABDECKUNG	COVER
A009.000	1	75952-038.09		KAPPE	CAP
A012.000		19772-196.00		CD-WECHSLERKABEL	CD CHANGER CABLE
A015.000		75952-038.65		MAGAZIN KPL. MCD30	MAGAZINE CPL. MCD 30
C002.000	2	75952-038.16		ZAHNRAD A	GEAR WHEEL A
C003.000	2	75952-038.17		ZAHNRAD B	GEAR WHEEL B
C004.000	2	75952-038.18		ZAHNRAD C	GEAR WHEEL C
C005.000	2	75952-038.76		SCHEIBE	WASHER
C006.000	2	75952-038.77		SCHEIBE	WASHER
C007.000	2	75954-033.02		MOTOR KPL.	MOTOR CPL.
C031.000	2	75954-033.30		ZAHNRAD, D	GEAR WHELL, D
C048.000	2	75952-038.19		MOTOR KPL.	MOTOR CPL.
C050.000	2	75954-033.04		ZAHNRAD, LA	GEAR WHELL, LA
C051.000	2	75954-033.05		ZAHNRAD, LB	GEAR WHELL, LB
C052.000	2	75952-038.23		ZAHNRAD, G	GEAR WHEEL, G
C053.000	2	75954-033.09		SPEZIAL SCHEIBE	SPEZIAL WASHER
C054.000	2	75954-033.06		MOTOR KPL.	MOTOR CPL.
C056.000	2	75954-033.07		ZAHNRAD, FB	GEAR WHEEL, FB
C067.000	2	75953-506.06		SCHALTER	SWITCH
C076.000	2	75954-033.08		MOTOR CPL.	MOTOR CPL.
C078.000	2	75953-506.06		SCHALTER	SWITCH
C087.000	2	75954-033.10		LASER EINHEIT	LASER UNIT
C110.000	2	75952-038.13		ZAHNRAD, H	GEAR WHEEL, H
C130.000	2	75953-506.06		SCHALTER	SWITCH
		72010-744.75		BEDIENUNGSANLTG.10SPR. B	INSTRUCTION MANUAL B
		72010-748.30		SERVICE MANUAL D/GB	SERVICE MANUAL D/G

POS. NR. POS. NO.	SACHNUMMER PART NUMBER	BEZEICHNUNG DESCRIPTION
D 502	75952-022.06	DIODE DCC 010
D 503	75953-506.23	DIODE DCA 010
D 550	8309-701-217	Z DIODE BZX 55 B8 V2 2%
D 700	75952-041.54	Z DIODE DZD 8.2 Y
D 801	8309-720-067	Z DIODE 6.8 B 0.5W
D 802	75952-041.68	DIODE DSB 010
D 803	75952-041.68	DIODE DSB 010
D 804	75952-022.06	DIODE DCC 010
D 805	75952-041.68	DIODE DSB 010
D 806	75952-041.68	DIODE DSB 010
D 807	75952-041.68	DIODE DSB 010
D 850	75952-041.54	Z DIODE DZD 8.2 Y
D 910	75952-041.85	OPTOKOPPLER GP 1S 5V/ OPTOCOUPLER
IC 501	75952-041.45	IC S 81250 HG-RD-T2
IC 551	75952-041.50	IC L 78 M 05 T
IC 601	75954-033.17	IC LC 78620E-D
IC 650	75954-033.18	IC LA9230MS
IC 651	75954-033.19	IC BA6999FP
IC 701	75952-041.91	IC NUM 4558 M
IC 702	75952-041.91	IC NUM 4558 M
IC 801	75954-033.13	IC LC66358B-4G21
IC 802	75952-041.57	IC S 8054 HN-CB
IC 803	75954-033.15	IC PST9138N
IC 804	75952-041.79	IC TC 7 SU 04 F
IC 850	75952-041.53	IC LB 1644
Q 550	75954-033.11	TRANSISTOR 2SD2199R
Q 601	75954-033.21	TRANS. 2SA1338-5

POS. NR. POS. NO.	SACHNUMMER PART NUMBER	BEZEICHNUNG DESCRIPTION
Q 602	75952-041.74	TRANS.UN 2215
Q 700	75952-041.93	TRANS.2 SC 2812 L 6
Q 701	75952-041.42	TRANS.2 SA 1341 TA
Q 702	75952-041.74	TRANS.UN 2215
Q 703	75952-041.74	TRANS.UN 2215
Q 801	75952-041.93	TRANS.2 SC 2812 L 6
Q 802	75987-459.61	TRANS.-WIDERST.UN 2114
Q 803	75952-041.63	TRANS.DTC 124 XK
Q 804	75952-041.64	SMD-TRANS. 2SB 1202 S
Q 805	75953-501.46	SMD-TRANS. 2 SA 1179 M6
Q 901	75952-041.80	FOTO-DIODE PT 4850 F/ PHOTO DIODE PT 4850 F
RA 651	75954-033.12	RESISTOR 4X27K
SVR 651	75954-033.20	ESTR 100 KOHM
SW 1	75953-506.06	SCHALTER / SWITCH
SW 801	75952-041.59	TAKTSCHALTER / TACT SWITCH
SW 802	75954-033.16	SCHIEBESCHALTER / SLIDE SWITCH
SWPCB 6	75954-033.14	SCHALTER / SWITCH
TH 801	75952-041.82	NTC CS 20123 BH 102 KCTH1
X 601	75953-506.29	QUARZ 16,9344 MHZ / QUARTZ
X 801	75953-506.27	QUARZ 4,190 MHZ / QUARTZ

1

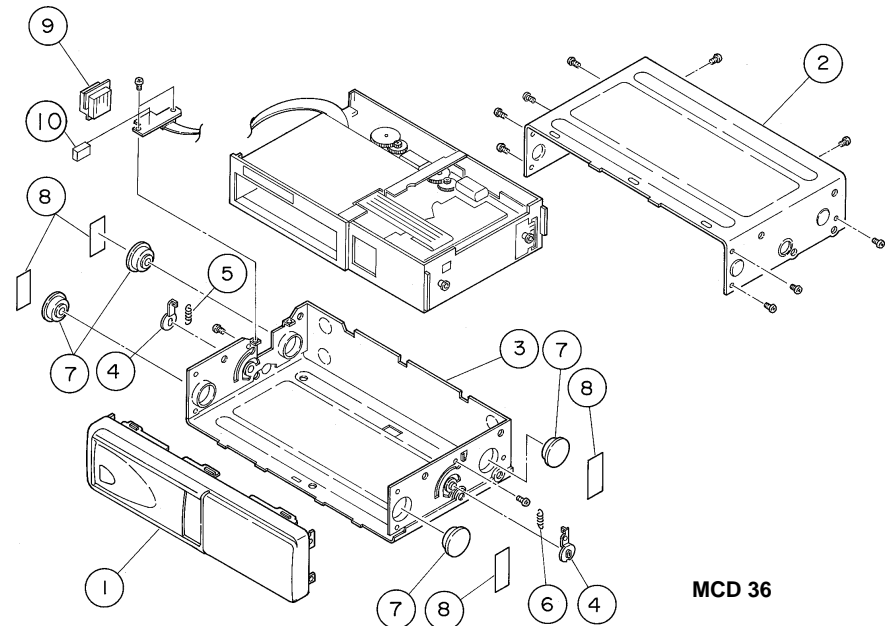

MCD 36

2

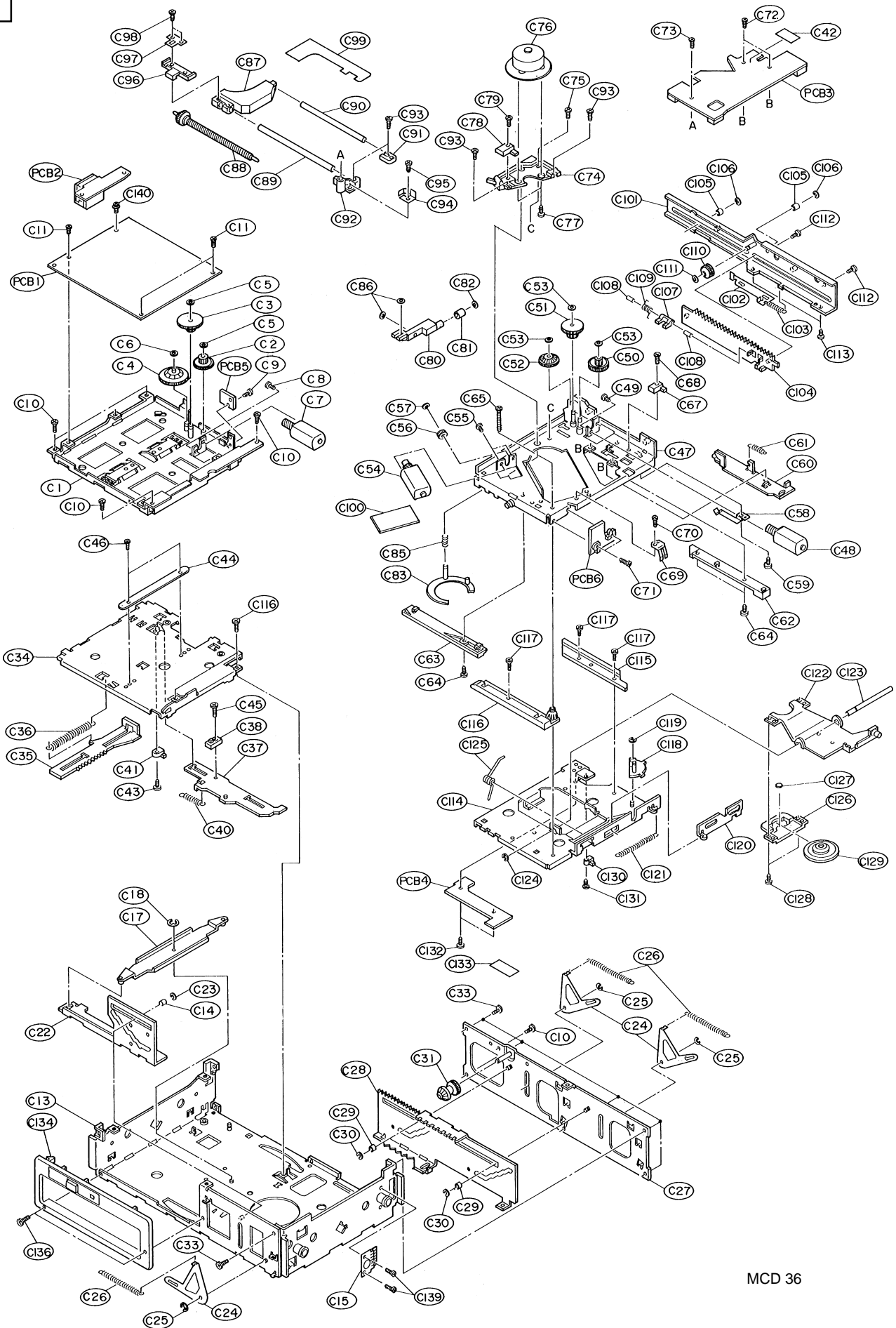

MCD 36

GRUNDIGErsatzteilliste
Spare Parts List

D Btx * 32700 #

12 / 95

MCD 40

SACH-NR. / PART NO.: 9.18337-8151, BESTELL-NR. / ORDER NO.: G.HF 0400
SACH-NR. / PART NO.: 75.1118-1051, BESTELL-NR. / ORDER NO.: G.HF 2900

POS. NR. POS. NO.	ABB. FIG.	SACHNUMMER PART NUMBER	ANZ. QUA.	BEZEICHNUNG D	DESCRIPTION GB
72008-849.99 TAUSCHGERAET EXCHANGE SET					
A001.000	1	75954-033.22		GEHAEUSE VORDETEIL	HOUSING FRONT
A002.000	1	75954-033.23		GEHAEUSE-OBERTeil	CABINET TOP
A003.000	1	75954-033.24		GEHAEUSE BODEN	HOUSING BOTTOM
A004.000	1	75954-033.25		HEBEL	LEVER
A005.000	1	75954-033.26		FEDER LINKS	SPRING LEFT
A006.000	1	75954-033.27		FEDER RECHTS	SPRING RIGHT
A007.000	1	75952-038.07		DAEMPfung	DAMPING OR ATTENUATION
A008.000	1	75952-038.08		ABDECKUNG	COVER
A009.000	1	75954-033.28		GUMMIPUFFER	CASHION RUBBER
A010.000	1	75952-038.09		KAPPE	CAP
A012.000		19772-196.00		CD-WECHSLERKABEL	CD CHANGER CABLE
A015.000		75954-033.01		MAGAZIN KPL.	MAGAZINE CPL.
C002.000	2	75952-038.16		ZAHNRAD A	GEAR WHEEL A
C003.000	2	75952-038.17		ZAHNRAD B	GEAR WHEEL B
C004.000	2	75952-038.18		ZAHNRAD C	GEAR WHEEL C
C005.000	2	75952-038.76		SCHEIBE	WASHER
C006.000	2	75952-038.77		SCHEIBE	WASHER
C007.000	2	75954-033.02		MOTOR KPL.	MOTOR CPL.
C028.000	2	75954-033.03		ZAHNRAD, PLATTE	GEAR WHEEL, BOARD
C039.000	2	75953-506.06		SCHALTER	SWITCH
C048.000	2	75952-038.19		MOTOR KPL.	MOTOR CPL.
C050.000	2	75954-033.04		ZAHNRAD, LA	GEAR WHEEL, LA
C051.000	2	75954-033.05		ZAHNRAD, LB	GEAR WHEEL, LB
C052.000	2	75952-038.23		ZAHNRAD, G	GEAR WHEEL, G
C053.000	2	75954-033.09		SPEZIAL SCHEIBE	SPECIAL WASHER
C054.000	2	75954-033.06		MOTOR KPL.	MOTOR CPL.
C056.000	2	75954-033.07		ZAHNRAD, FB	GEAR WHEEL, FB
C067.000	2	75953-506.06		SCHALTER	SWITCH
C076.000	2	75954-033.08		MOTOR CPL.	MOTOR CPL.
C078.000	2	75953-506.06		SCHALTER	SWITCH
C087.000	2	75954-033.10		LASER EINHEIT	LASER UNIT
C110.000	2	75952-038.13		ZAHNRAD H	GEAR WHEEL, H
C130.000	2	75953-506.06		SCHALTER	SWITCH
		72010-744.80		BEDIENUNGSANLTG.10-SPR. B	INSTRUCTION MANUAL B
		72010-748.30		SERVICE MANUAL D/GB	SERVICE MANUAL D/GB

POS. NR. POS. NO.	SACHNUMMER PART NUMBER	BEZEICHNUNG DESCRIPTION
D 502	75952-022.06	DIODE DCC 010
D 503	75953-506.23	DIODE DCA 010
D 550	8309-701-217	Z DIODE BZX 55 B8 V2 2%
D 700	75952-041.54	Z DIODE DZD 8.2 Y
D 801	8309-720-067	Z DIODE 6,8 B 0,5V
D 802	75952-041.68	DIODE DSB 010
D 803	75952-041.68	DIODE DSB 010
D 804	75952-022.06	DIODE DCC 010
D 805	75952-041.68	DIODE DSB 010
D 806	75952-041.68	DIODE DSB 010
D 807	75952-041.68	DIODE DSB 010
D 850	75952-041.54	Z DIODE DZD 8.2 Y
D 910	75952-041.85	OPTOKOPPLER GP 1S 5V/ OPTOCOUPLER GP 1S 5V
IC 501	75952-041.45	IC S 81250 HG-RD-T2
IC 551	75952-041.50	IC L 78 M 05 T
IC 601	75954-033.17	IC LC 78620E-D
IC 650	75954-033.18	IC LA9230MS
IC 651	75954-033.19	IC BA6999FP
IC 701	75952-041.91	IC NUM 4558 M
IC 702	75952-041.91	IC NUM 4558 M
IC 801	75954-033.13	IC LC66358B-4G21
IC 802	75952-041.57	IC S 8054 HN-CB
IC 803	75954-033.15	IC PST9138N
IC 804	75952-041.79	IC TC 7 SU 04 F
IC 850	75952-041.53	IC LB 1644
Q 550	75954-033.11	TRANSISTOR 2SD2199R
Q 601	75954-033.21	TRANS. 2SA1338-5

POS. NR. POS. NO.	SACHNUMMER PART NUMBER	BEZEICHNUNG DESCRIPTION
Q 700	75952-041.93	TRANS.2 SC 2812 L 6
Q 701	75952-041.42	TRANS.2 SA 1341 TA
Q 702	75952-041.74	TRANS.UN 2215
Q 703	75952-041.74	TRANS.UN 2215
Q 801	75952-041.93	TRANS.2 SC 2812 L 6
Q 802	75987-459.61	TRANS.-WIDERST.UN 2114
Q 803	75952-041.63	TRANS.DTC 124 XK
Q 804	75952-041.64	SMD-TRANS. 2SB 1202 S
Q 805	75953-501.46	SMD-TRANS. 2 SA 1179 M6
Q 901	75952-041.80	PHOTO DIODE PT 4850 F
RA 651	75954-033.12	RESISTOR 4X27K
SVR 651	75954-033.20	ESTR 100 KOHM
SPCB 6	75954-033.14	SCHALTER / SWITCH
SW 801	75952-041.59	TAKTSCHALTER
SW 802	75954-033.16	TACT SWITCH SCHIEBESCHALTER / SLIDE SWITCH
TH 801	75952-041.82	NTC CS 20123 BH 102 KCTH1
X 601	75953-506.29	QUARZ 16,9344 MHZ / QUARTZ
X 801	75953-506.27	QUARZ 4,190 MHZ / QUARTZ

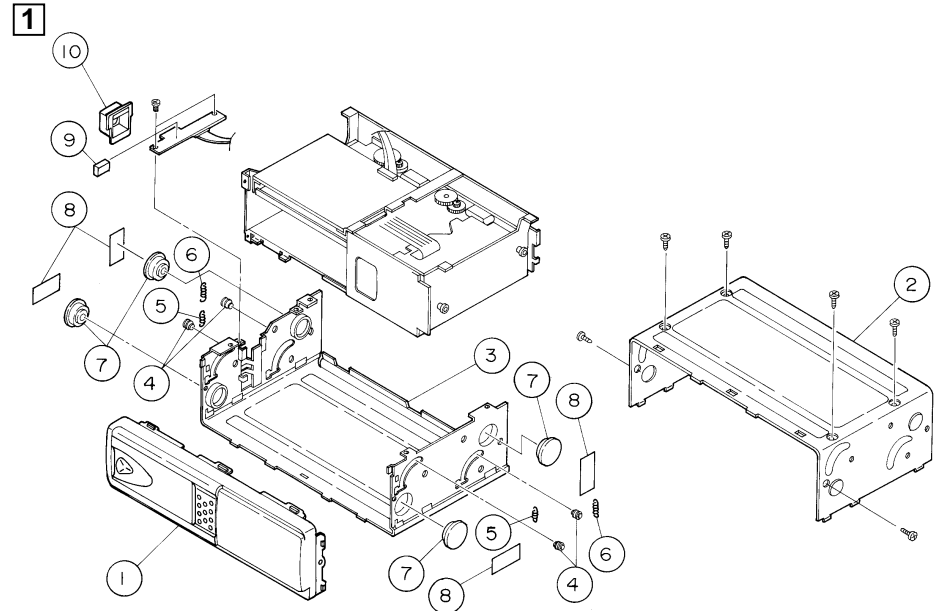

MCD 40

2

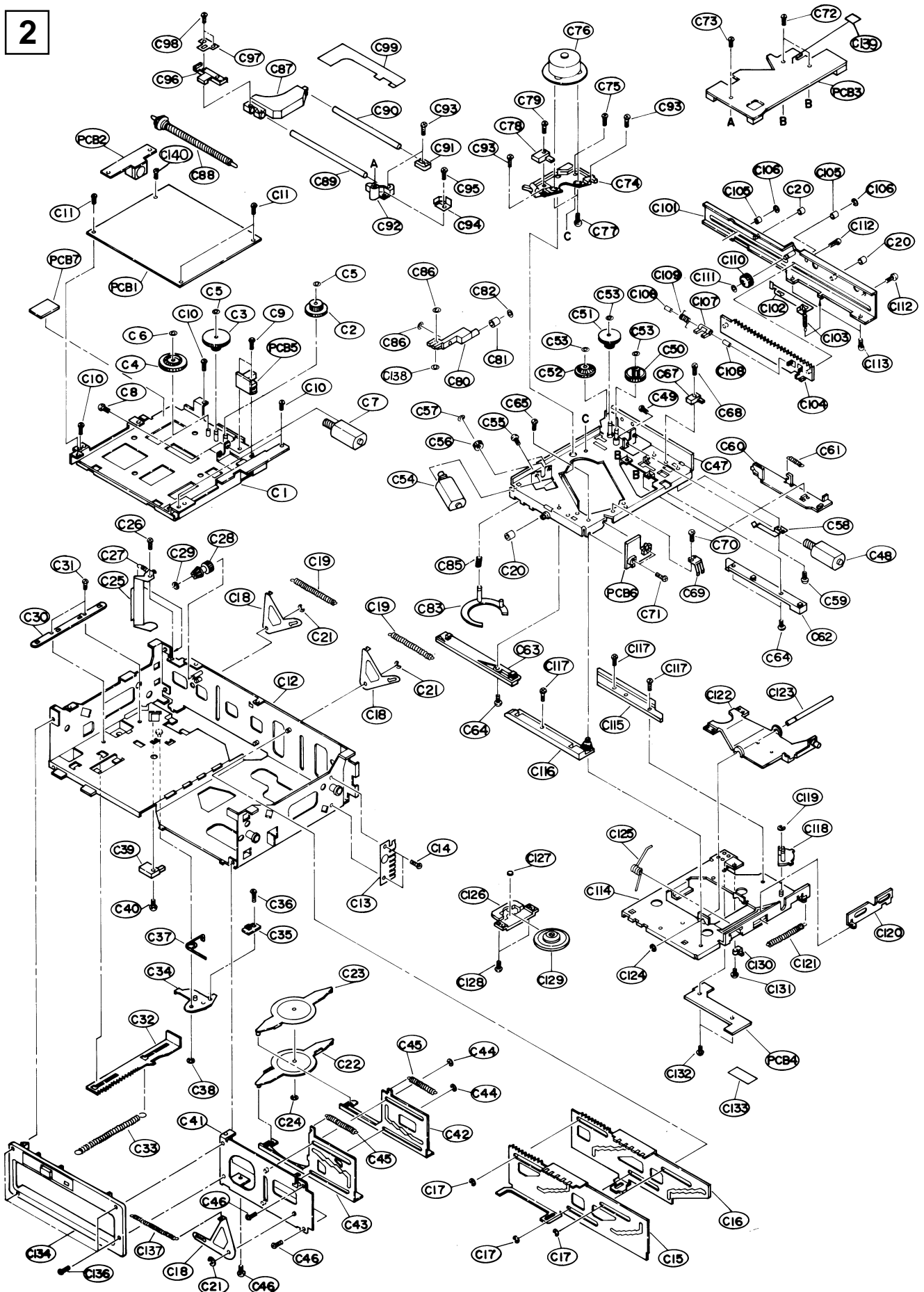

MCD 40