

# Simpson

INSTRUMENTS THAT STAY ACCURATE

Quality is the indispensable component  
of every Simpson instrument . . . . .

## OPERATOR'S MANUAL

IN CIRCUIT  
CAPACOHMETER  
MODEL 383A

**SIMPSON ELECTRIC COMPANY**

5200 W. Kinzie St., Chicago 44, Illinois, ES 9-1121

In Canada, Bach-Simpson, Ltd., London, Ontario

## ERRATA

Page 28. - "Calibrating Capacitance Ranges"

Set function switch to 1000 MMFD range,  
short leads #2 and #3 together.

Adjust meter adjust knob for full scale  
meter deflection.

Set function switch to .1 MFD range,  
short leads #2 and #3 together.

Adjust R16 for full scale meter deflection.  
R 16 is located on chassis near 2050  
tube.

Capacitance measuring circuit is now  
calibrated and all capacitance ranges  
will track on the capacitance scale.

Simpson Electric Company  
5200 W. Kinzie St., Chicago 44, Illinois  
Es. 9-1121

# PANEL METERS

by  
*Simpson*

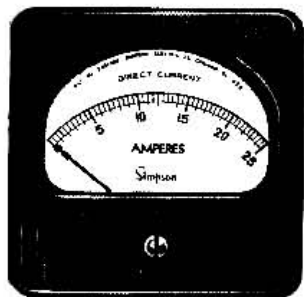

MODELS 27, 37, 47, 57  
3½" RECTANGULAR  
ACCURACY: 2%  
SCALE LENGTH: 2-9/16"



SIMPSON MODERNISTIC  
"CLEAR-VUE"  
BUILT TO SPECIAL ORDER  
2½", 3½", 4½", 5½" SIZES

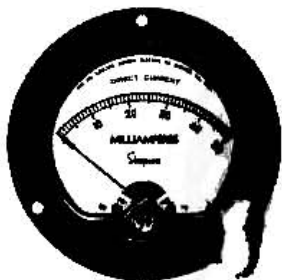

MODELS 25, 35, 45, 55  
3½" ROUND, ACCURACY: 2%  
SCALE LENGTH: 1-7/8"  
ALSO AS MODELS 125, 135,  
145 AND 155 - ALL 3½"  
ROUND. SCALE 1-7/8"

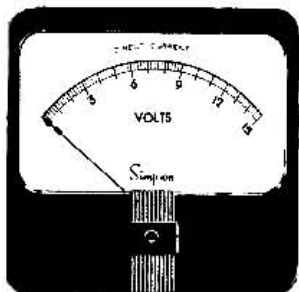

MODELS 29, 39, 49, 59  
4½" RECTANGULAR  
ACCURACY: 2%  
SCALE LENGTH: 3-29/32"

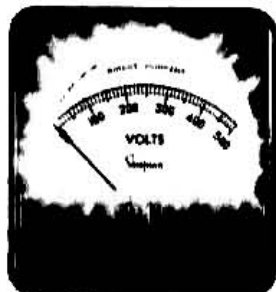

MODELS 27, 37, 57  
ILLUMINATED  
3½" RECTANGULAR  
ACCURACY: 2%  
SCALE LENGTH: 1-5/16"



MODELS 127, 137, 147,  
157,  
2½" RECTANGULAR  
ACCURACY: 2%  
SCALE LENGTH: 1-7/8"

## OPERATOR'S MANUAL

## SIMPSON

## IN-CIRCUIT

## CAPACOHMETER

## MODEL 383A

**SIMPSON ELECTRIC COMPANY**

5200 W. KINZIE ST., CHICAGO 44, ILLINOIS. ESTEBROOK 9-1121

IN CANADA, BACH-SIMPSON, LTD., LONDON, ONTARIO

NEARLY 800 DIFFERENT SIZES AND KINDS OF SIMPSON PANEL METERS ARE AVAILABLE FROM YOUR ELECTRONIC PARTS JOBBER. WHETHER YOU NEED ONE PANEL METER ..... OR A DOZEN ..... LOOK FOR THE FAMILIAR ORANGE COLORED SIMPSON BOX. FOR FURTHER INFORMATION WRITE SIMPSON ELECTRIC CO., 5200 W. KINZIE ST., CHICAGO 44, ILL., ESTEBROOK 9-1121.



## SECTION I

### GENERAL DESCRIPTION

The Simpson Capacohmeter Model 383A is a combination of three basic instruments into a single cabinet. These instruments each perform a different type of test on capacitors. All three work together to provide the most conclusive series of capacitor evaluations available.

### TYPES OF TESTS

#### MEASURING CAPACITANCE

One of the measurements which is essential for determining the quality of a capacitor is its capacitance. The Simpson Capacohmeter Model 383A indicates capacitance on a direct-reading meter scale. There are five ranges for capacitance measurements from 10 micro-microfarads (MMFD) to 10 microfarads (MFD). This wide range includes most ceramic, mica, paper, oil-filled, and air dielectric types of capacitors.

#### MEASURING LEAKAGE RESISTANCE

A second measurement which is of importance for evaluating capacitors is the amount of leakage resistance. Ordinarily, a capacitor is assumed to have almost infinite resistance between its two plates, or electrodes. Actually, there is always some high resistance DC path between the plates because there is no such thing as a "perfect" insulator. The resistance of the DC path in a good capaci-



FIGURE 1. SIMPSON CAPACOHMETER MODEL 383A

## TYPES OF TESTS

tor is measurable in megohms, so the Simpson Capacohmeter has a megohms measuring circuit.

Deterioration and damages, both physical and electrical, will reduce the original high leakage resistance to a lower value during the life of the capacitor. The lower limit of leakage resistance value at which the capacitor is still usable depends on a number of factors.

There is no definite numerical value of leakage resistance that can be assigned, wherein all capacitors having a higher value of leakage resistance are GOOD, and those having lower leakage resistance are BAD. Rather we must consider the leakage resistance in relationship to the circuit containing the capacitor in question.

Nevertheless, as a relative measurement, the megohms indications are a wonderful aid in determining faulty components.

The megohmmeter portion of the Simpson Capacohmeter may be used separately to measure high resistance for many applications other than capacitors. See Section IV for some suggested applications.

### **PULSE TESTING**

Many capacitors will respond normally to the first two tests which can be made with the Simpson Capacohmeter, and still will not perform satisfactorily when they are placed in service. This is true because the nature of the circuit into which they are connected is very different from the testing circuit. For the capacity measurement circuit, there is a sine wave AC voltage which is applied to the capacitor. For the megohms measurement, a DC voltage is applied to

## TYPES OF TESTS

the capacitor.

To complete the types of voltages which are applied for testing, a narrow pulse voltage is applied from a relaxation oscillator in the Simpson Capacohmeter. The amount of peak voltage in the pulse is variable with a front panel control, and the amount applied for each test is related to the amount of voltage stress which the capacitor is rated to withstand.

If the capacitor is in good condition, the application of a safe value of pulse voltage will not affect it in any way. But if the capacitor is weak, or is about to become defective, the pulse voltage will cause an internal change in the capacitor which will change the meter indication.

### **IN-CIRCUIT CHECKS**

Most installed capacitors can be checked without removal from their circuits. This is a distinct advantage over previous testing procedures which require that the capacitor be isolated from the circuit by unsoldering a lead. The limitation on this use is the case where a capacitor is in parallel with a low resistance or low reactance component. However, with the Model 383A, most capacitors can be tested without any unsoldering or clipping of leads. This facility is of particular value in checking printed circuits and plated circuits.

For convenience, there is a special circuit, requiring the third lead on the Capacohmeter, for testing coupling capacitors without removal from the circuit. The controlled voltage is injected on the input side of the coupling capacitor circuit, and the results are measured on the output side of

## TYPES OF TESTS

the capacitor.

### **CAPACITY MEASURING CIRCUITS**

There are five ranges for measuring capacitance values. Each range is identified by the full scale value. The ranges and their applications are as follows:

- 1000 MMFD - for measuring values up to 1000 micro-microfarads
- .01 MFD - for values from .001 to .01 microfarad (1000 to 10,000 micro-microfarads)
- .1 MFD - for values from .01 to .1 microfarad
- 1. MFD - for values from .1 to 1 microfarad
- 10 MFD - for values from 1 to 10 microfarads

The accuracy of the Capacohmeter for capacity measurements is  $\pm 10\%$  for indications between 1.0 and 10.0 MFD marks on the red arc at the top of the dial. Indications obtained in the left hand portion of the dial, below the 1.0 mark, have a reduced accuracy. Use the portion of the scale below 1.0 for relative indications only.

### **MEGOHMMETER CIRCUIT**

The megohmmeter circuit in the Simpson Capacohmeter Model 383A applies a DC voltage across a resistance measuring circuit. The amount of resistance between the test leads is indicated on the black arc of the dial which is below the capacity arc. The first mark on the resistance arc (1K) is for 1000 megohms, and further meter pointer deflection indicates less resistance. The extreme right hand side of the arc indicates zero ohms.

## TYPES OF TESTS

In use, the megohmmeter circuit is first set up like any ordinary ohmmeter circuit. The test leads are first clipped together while the METER ADJUST control is set for full scale deflection. Then the test leads are separated and connected across the capacitors, circuit, or resistance which is to be measured.

### **METER SENSITIVITY**

When a coupling capacitor is to be tested in its circuit, all three leads from the Model 383A are connected into the circuit. Because there is a possible shunt DC circuit for this type of application, the leakage resistance indication may be affected by the shunt circuit. A special spring-loaded switch at the upper left hand corner of the front panel will temporarily change the meter sensitivity to provide a more accurate indication of the leakage resistance in such a condition. See the operating instructions for further information.

### **PULSE TEST CIRCUIT**

As described above, the pulse test circuit is used to identify capacitors which will not operate properly when they are in pulse circuits, even though they respond satisfactorily to a sine wave or DC voltage application. It will also cause controlled damage in capacitors which are about to break down, and will identify the fact that they are no longer usable.

The pulses are formed in a relaxation oscillator circuit, using a four element thyatron tube. The PULSE VOLTAGE control sets the amount of grid driving voltage for the thyatron, which in turn determines the amplitude of pulses

## TYPES OF TESTS

available for the tests. This front panel control is marked for the peak value of pulse voltage which results from each setting of the control knob.

A capacitor, when it is bombarded with a series of sharp pulses, will change its internal characteristics if it is not in first-class operating condition. If the capacitor can not respond to pulses, the Capacohmeter will indicate this condition. If the amplitude of the applied pulses, which should be adjusted to 150% of the rated voltage for which the capacitor was built, is too much for the condition of the dielectric, there will be a breakdown within the capacitor and this will show on the meter of the Capacohmeter.

The inner arc of the meter on the Capacohmeter has a narrow portion marked GOOD. If, after a short pulsing period, there is a change within the capacitor under test, the pointer will move away from the GOOD area either to the left or to the right. A short swing away from the GOOD area followed by an immediate return to it is normal for larger values of capacitance. But if the pointer does not return to the GOOD area, this indicates that the capacitor is defective and should be replaced.

Most capacitors can be checked without removal from the circuit of which they are a part. However, a capacitor which is connected in a circuit with a comparatively low resistance or reactance in parallel can produce erratic results. When there is any doubt, isolate the capacitor by removing one of its leads, and apply the pulses to the capacitor alone.

## GENERAL DESCRIPTION

### **FRONT PANEL**

The equipment on the front panel of the Simpson Capacohmeter Model 383A and the purpose for each is as follows:

### **FUNCTION SWITCH**

The FUNCTION switch, at the lower right corner, determines the type of circuit for which the instrument is set. It has five positions for the five ranges of capacity measurements, marked with the full-scale value of capacitance for each range. These are 1000 MMFD, .01 MFD, .1 MFD, 1. MFD, and 10 MFD. There is one position marked MEG  $\Omega$ , for the megohmmeter circuit. There is also a position marked PULSE, for the pulse testing circuit.

### **TEST LEAD JACKS**

There are three test lead jacks, marked 1, 2, and 3. These are color coded to assure proper use and applications. Jacks 2 and 3 are used for the test leads for all applications of the instrument. Jack 1 is used for the third lead when testing coupling capacitors in-circuit.

Jack 1 is black, and is used to connect one of the black test leads. Jack 2 is red, and is used to connect the red test lead. Jack 3 is green, and is used to connect the other black test lead. Although black test leads are used for both the black (Jack 1) and the green (Jack 3) contacts, there will be no reason to have a lead connected in jack 1 except when it is in use, so there will be a minimum amount of difficulty in identification.

## GENERAL DESCRIPTION

For simplification of instructions, the black test lead which is connected in the green contact jack will be referred to as the green test lead.

In use, the red and green test leads are to be connected across the capacitor under test for all measurements. The test lead which is connected in the black contact jack (jack 1) will be added to these for testing coupling capacitors while they are in their circuits.

### **METER ADJUST CONTROL**

The control at the upper right on the front panel is called METER ADJUST. It has an OFF position. Use this control to turn the instrument on and off, and to adjust for variations in line voltage.

When the FUNCTION switch is set at any capacitance range or at MEG  $\Omega$  (any position except PULSE), short the red and green test leads together and set the METER ADJUST control for full scale meter deflection. Then proceed with the tests.

### **PULSE VOLTAGE CONTROL**

The control at the lower left is called PULSE VOLTAGE, and is marked with values from 100 to 900. These are the peak voltages of the pulses which will be present between the red and green test leads when the FUNCTION switch is set at PULSE.

When a pulse test is to be applied to a capacitor, check the voltage rating for the capacitor and set the PULSE VOLTAGE control according to that voltage.

## GENERAL DESCRIPTION

### **METER SENSITIVITY SWITCH**

When the leakage resistance in a coupling capacitor is being tested in-circuit, there is a possible shunt circuit around the capacitor. To offset this and to provide a more accurate indication of the capacitor condition, the METER SENSITIVITY switch on the front panel will change the sensitivity of the meter circuit temporarily. It is a spring-loaded switch which will change the sensitivity of the circuit only while it is being held in the on position. Then the circuit will return to its normal condition for further use.

### **FUSE**

There is a fuse on the front panel, which is in series with the black test lead (jack 1). If this lead is connected accidentally in a circuit so the current through it exceeds its rated value of 1/8 ampere, the fuse will blow to protect the circuit.

The fuse is mounted in an extractor type fuseholder. Whenever there is any question concerning the fuse condition, unscrew the cover and remove the fuse for inspection. If it has been blown, replace it with another type 3AG fuse with a 1/8 ampere rating.

### **PILOT LAMP**

The pilot lamp, located near the FUNCTION switch, will glow whenever power is applied to the circuits in the Capacohmeter. If the power cord is connected and the instrument is turned on, but the pilot lamp does not glow, the



## GENERAL DESCRIPTION

main fuse, located inside the case, may be blown. See Section III, Maintenance, for further information.

### METER

The indicating meter, centrally located at the top of the front panel, has three arcs. The top arc, marked in red, indicates capacitance for quantitative measurements. The black arc below it shows the number of megohms for high resistance and leakage measurements. The inner arc has a small area marked GOOD, and the balance of the arc is for BAD indications for pulse testing applications.

The zero mark for the pointer is not at the extreme left-hand side of the meter, as is usual; it is at the GOOD mark which corresponds to zero on the capacity arc. Do not attempt to set the pointer for mechanical zero at the extreme left hand side of the meter, but rather zero it at the ZERO mark on the capacitance arc.

The basic meter is one of the famous Simpson INSTRUMENTS THAT STAY ACCURATE. It has a sensitivity of 50 microamperes full scale. It is ruggedly built, but is subject to damage if it is dropped or is seriously mishandled. It is built with the precision of a fine watch and should be considered and handled with respect.

### TEST LEADS

There are three test leads with banana type plugs which are furnished with each Capacohmeter. There are two black leads and one red lead. One black test lead connects into the green contact on the front panel (jack 3) and the red test lead connects into the red contact on the front panel

## GENERAL DESCRIPTION

(jack 2). These two leads will be used for all tests with the Capacohmeter.

The third test lead, which is the other black one, connects into the black contact (jack 1) on the front panel. This is to be connected only at the time when it is needed for in-circuit measurements of coupling capacitors. See operating instructions.

### DIMENSIONS AND WEIGHT

The case of the Simpson Capacohmeter Model 383A measures 8x11x8½ inches. It weighs 11½ pounds. The shipping weight, complete with an instruction book and three test leads, is 13 pounds.

### POWER REQUIREMENTS

The Simpson Capacohmeter Model 383A is designed for use with a power input of 100 to 125 volts, single phase 60-cycle AC only. Normal power consumption is 10 watts. Although the input voltage may be any value through this wide range, power line voltage fluctuations will reflect inaccurate measurement indications unless the instrument is adjusted for each change in input voltage.

## SECTION II

### OPERATION

#### USE OF TEST LEADS

There are three test leads which are furnished with the Simpson Capacohmeter Model 383A. Two are black and the

## OPERATION

third is red. For most applications, only the red and one of the black test leads are to be used. Connect the red test lead in the red contact (marked jack 2) on the front panel, and the black test lead in the green contact (marked jack 3). For convenience in following instructions, the test lead which is connected in the green contact (jack 3) will be called the green test lead.

When the Capacohmeter is to be used to test coupling capacitors connected in their operating circuits only, the other black test lead is used in the black contact (marked jack 1) on the front panel. To prevent confusing this lead with the "green test lead", leave it disconnected from the Capacohmeter except during the times when it is actually in use.

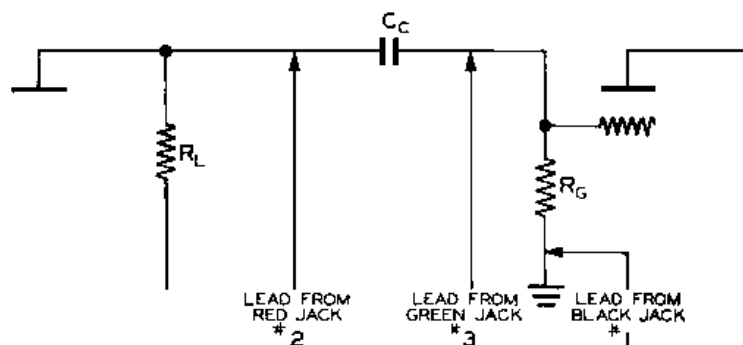

FIGURE 2. CONNECTIONS FOR MEASUREMENTS OF COUPLING CAPACITORS IN-CIRCUIT

## OPERATION

### THREE LEAD CONNECTIONS

Figure 2 shows how the three leads are to be connected in a coupling capacitor circuit when the coupling capacitor is to be tested in-circuit. This is the only place where all three leads will be used. In all other cases, the red and green test leads will be used and the black test lead should be disconnected from the Capacohmeter.

### MEASURING CAPACITY

The Simpson Capacohmeter Model 383A will measure capacity in micro-microfarads or in microfarads on a direct reading meter scale for mica, ceramic, paper, oil-filled, or air dielectric capacitors. There are five convenient ranges for capacity measurements, with the full-scale value for each range identified at the switch position for that range.

### MEASURE IN-CIRCUIT OR ISOLATED CAPACITORS

Capacitance measurements may be made either in-circuit or out of circuit. The limitations on in-circuit measurements will be the amount of shunt resistance, because any parallel path will allow more current to flow through the meter circuit, with an increased meter indication resulting. The table below shows the minimum value of shunt resistance which can be in a circuit to limit errors to 10%.

Capacitance in Microfarads	Minimum Shunt Resistance
0.01	3 megohms
0.02	2.5 megohms
0.05	1 megohm
0.1	500 K
0.22	450 K

## OPERATION

0.47	350 K
1.0	250 K
2.2	200 K
5.0	150 K
10.0	100 K

Capacitance measurements may be made in-circuit regardless of the amount of shunt resistance without endangering the instrument. The error in indications is the only undesirable result.

### TURN OFF CIRCUIT POWER

As a protection to both the operator and the Capacohmeter, always be sure the equipment in which an in-circuit capacitance checks is to be made is turned off and the capacitors are discharged.

When there is any doubt as to the circuit condition, isolate the capacitor from its circuit and read its capacitance.

Step-by-step the procedure for either isolated or in-circuit capacitance measurements is as follows:

1. Connect the red test lead into the red contact on the front panel (jack 2), and one of the black test leads into the green contact on the front panel (jack 3). For convenience, the lead which is connected into the green contact will be referred to as the green test lead.
2. Set the FUNCTION switch at one of the capacity range positions. These are marked 1000 MMFD, .01 MFD, .1 MFD, 1. MFD, and 10 MFD.
3. Connect the power plug into a source of 100 to 125

## OPERATION

volts, single phase 60 cycle AC power. Rotate the METER ADJUST control clockwise to turn on the instrument. The pilot lamp should glow to indicate an on condition.

4. After a short warm-up time, connect the ends of the two test leads together. The meter pointer should read full scale. Set the METER ADJUST control for a full scale indication. The Capacohmeter is now ready for use.
5. Separate the test leads and connect them across the capacitor which is to be measured. Set the FUNCTION switch at the capacity range position which will provide a meter reading between 1.0 and 10.0 on the red arc at the top of the dial.

### NOTE

For capacitance values below 100 micro-microfarads (100 MMFD), indications will be between zero (the GOOD mark) and 1.0 when the FUNCTION switch is set at 1000 MMFD. These indications are relative only.

6. Read the red arc on the dial.  
For the 1000 MMFD range, multiply the reading by 100 for micro-microfarads.  
For the .01 MFD range, multiply the reading by 1000 for micro-microfarads, or divide by 1000 for microfarads.  
For the .1 MFD range, multiply the reading by 10,000 for micro-microfarads, or divide by 100 for micro-

## OPERATION

farads.

For the 1. MFD range, divide the reading by 10 for microfarads.

For the 10. MFD range, read the value directly in microfarads.

### NOTE

For the best accuracy in capacity readings, recheck the full scale meter indication with the test leads shorted together just before a final reading. Reset the METER ADJUST control, if required, for exactly full scale deflection.

## MEASURING CAPACITORS IN-CIRCUIT

Coupling capacitors may be measured in-circuit, providing the grid resistor has a value at least as great as the "Minimum Shunt Resistance" listed in the table on page 15. Each possible value of coupling capacitance will require a different minimum grid resistor value in order to produce readings with minimum error.

Use the following procedure.

1. Connect the red test lead to the red contact (jack 2); and connect the black test lead to the green contact (jack 3). The test lead which is connected in the green contact (jack 3) will be referred to as the green test lead for convenience.
2. Set the FUNCTION switch at one of the capacitance range positions. These are marked 1000 MMFD, .01 MFD, .1 MFD, 1. MFD, and 10 MFD.

## OPERATION

3. Connect the power plug into a source of 100 to 125 volts, single phase 60 cycle AC power. Rotate the METER ADJUST control clockwise to turn on the instrument. The pilot lamp should glow to indicate when the Capacohmeter is turned on.
4. Check to see that power is turned off in the circuit in which the coupling capacitor is connected. Discharge the coupling capacitor.
5. After a short warm-up period, connect the ends of the red and green test leads together. The meter pointer should read full scale. Set the METER ADJUST control for a full-scale meter indication. The Capacohmeter is now ready for use.
6. Separate the red and green test leads. Connect the red test lead at the input for the coupling capacitor and the green test lead at the output for the coupling capacitor.
7. Set the FUNCTION switch at the capacitance range position which will provide a meter reading between 1.0 and 10.0 on the red arc at the top of the dial.
8. Read the red arc on the dial.  
For the 1000 MMFD range, multiply the reading by 100 for micro-microfarads.  
For the .01 MFD range, multiply the reading by 1000 for micro-microfarads, or divide by 1000 for microfarads.  
For the .1 MFD range, multiply the reading by 10,000 for micro-microfarads, or divide by 100 for micro-

## OPERATION

farads.

For the 1. MFD range, divide the reading by 10 for microfarads.

For the 10. MFD range, read the value directly in microfarads.

### NOTE

For the best accuracy in capacitance readings, re-check the full scale meter indication with the red and green test leads shorted together just before a final reading. Reset the METER ADJUST control, if required, for exactly full scale deflection.

### MEASURING LEAKAGE RESISTANCE

Leakage resistance is the direct-current path which exists between the plates of a capacitor. Theoretically, there is no path through which a direct current can pass. But actually, since there is no such thing as a "perfect" insulator, there will always be some very high measurable resistance between the plates, even when the capacitor is new.

Gradually, as the capacitor ages or is used, the value of resistance decreases. Occasionally a higher voltage is applied to the capacitor than it can withstand, and the dielectric is damaged. Whether the deterioration occurs quickly or gradually, the result is that the capacitor's usefulness becomes impaired because of its reduced ability to prevent the flow of direct current.

The direct-current path through a capacitor is called its "leakage resistance", and will normally be a very large

## OPERATION

amount - probably over 100 megohms. The Capacohmeter will identify a capacitor's leakage resistance directly on the meter scale. Judgement of the ability of the capacitor to continue to provide service in a circuit is still left to the service man. In general, however, when the leakage resistance begins to deteriorate to smaller and smaller values, there is very little useful life left in the capacitor.

To measure leakage resistance, use the following procedure:

1. Connect the red test lead in the red contact (jack 2); and one of the black test leads in the green contact (jack 3). If the leakage resistance is to be measured for a coupling capacitor in-circuit, connect the other black test lead in the black contact (jack 1). For convenience, the test lead which is connected in the green contact (jack 3) will be referred to as the green test lead.
2. Set the FUNCTION switch at MEG  $\Omega$ .
3. Connect the power plug into a source of 100 to 125 volts, single phase 60 cycle AC power. Rotate the METER ADJUST control clockwise to turn on the instrument. The pilot lamp should glow to indicate when the Capacohmeter is turned on.
4. Check to see that power is turned off in the circuit in which an in-circuit capacitor is connected. Discharge the capacitor.
5. After a short warm-up period, connect the ends of the red and green test leads together. The meter pointer



## OPERATION

should read full scale. Set the METER ADJUST control for a full scale meter indication. The Capacohmeter is now ready for leakage resistance measurements.

6. Separate the red and green test leads. If it is a coupling capacitor in-circuit, connect the red test lead on the input side of the capacitor and the green test lead on the side of the capacitor; then connect the black test lead to the circuit ground. See figure 2 for these connections.
7. Read the resistance directly under the meter pointer on the arc marked RESISTANCE MEGOHMS. If the leakage is being read for a coupling capacitor in-circuit and the first indication is 50 megohms or more, press the METER SENS switch for a more accurate reading.

## PULSE TESTING

There are two types of conditions which will be identified with the pulse testing applications of the Simpson Capacohmeter Model 383A. The first is the ability of the capacitor to respond to sharp pulses. The second is the ability of the dielectric in the capacitor to withstand large amounts of voltage.

## DYNAMIC TESTS

For a test of the capacitor's ability to respond to pulse voltage application, check the rated voltage for the capacitor and apply pulses which have that peak value for a short period of time. The relative capacitor rating will be

## OPERATION

shown on the inner arc of the meter on the Capacohmeter; this reads GOOD and BAD.

For the dynamic pulse test, proceed as follows:

1. Connect the leads to the Capacohmeter. Connect the red test lead in the red contact (jack 2), and one of the black test leads in the green contact (jack 3). For convenience, the test lead connected in the green contact will be referred to as the green test lead. If the pulses are to be applied to a coupling capacitor in-circuit, connect the other black test lead in the black contact (jack 1).
2. Set the FUNCTION switch to the MEG  $\Omega$  position.
3. Connect the power plug into a source of 100 to 125 volts, single phase 60 cycle AC power. Rotate the METER ADJUST control clockwise to turn on the instrument. The pilot lamp should glow to indicate when the Capacohmeter is turned on.
4. Check to see that power is turned off in the circuit in which an in-circuit capacitor is connected. Discharge the capacitor.
5. After a short warm-up period, connect the ends of the red and green test leads together. The meter pointer should read full scale. Set the METER ADJUST control for a full scale meter indication.
6. Separate the red and green test leads and connect them across the capacitor which is to be tested. If it is a coupling capacitor in-circuit, connect the red test lead on the input side of the capacitor and the green test lead on the output side of the capacitor.

## OPERATION

7. Set the PULSE VOLTAGE control in the lower left hand corner of the Capacohmeter at the rated voltage for the capacitor under test.
8. Turn the FUNCTION switch to PULSE and observe the inner arc of the meter. For large value capacitors, the pointer may swing away from the GOOD area of the meter and then return slowly to it; this is normal and does not indicate a bad capacitor. However, if the pointer moves out of the GOOD area and remains out of it after approximately 30 seconds of pulse application, the capacitor is bad and needs to be replaced.

### CAUTION

Do not touch the red and green test leads while the Capacohmeter is set for PULSE operation. The full value of peak voltage set on the PULSE VOLTAGE control is present between these leads.

9. To turn off the pulses, return the FUNCTION switch to MEG  $\Omega$ , or to one of the capacitance ranges.

## **BREAKDOWN TESTS**

There is a safety factor included in the voltage ratings for all capacitors. To test their actual ability to withstand voltage without breaking down, it is necessary to add 50% to the rated voltage, and apply pulse voltages with this greater strength.

If a capacitor fails on the dynamic test above, do not subject it to a breakdown test. But if it has passed the dynamic test, a final check for breakdown is made as follows:

## OPERATION

1. Follow the procedure for dynamic testing and leave the test leads connected to the capacitor.
2. Advance the PULSE VOLTAGE control to 150% of the rated voltage for the capacitor being tested. For example; set the PULSE VOLTAGE at 300 volts for a capacitor rated at 200 volts, or set the PULSE VOLTAGE at 900 volts for a 600 volt capacitor rating.
3. Turn the FUNCTION switch to PULSE and observe the meter indication. If the dielectric in the capacitor will withstand this high voltage without any breakdown, the meter reading will show GOOD. But, if there is any breakdown of the dielectric, the meter pointer will move out of the GOOD area and remain to show that the capacitor is bad.
4. To turn off the pulses, return the FUNCTION switch to MEG  $\Omega$ , or to one of the capacity range positions.

## **SECTION III**

### **MAINTENANCE**

#### **ZERO POINTER POSITION**

The normal position for the pointer with no power applied to the Simpson Capacohmeter Model 383A is near the left hand side of the dial, at the ZERO mark on the capacitance arc. Whenever the pointer does not rest over this mark with no power applied to the instrument, adjust the slotted

## MAINTENANCE

screw through the lower part of the meter cover to correct the condition. Turn the screw slowly either to the right or to the left until the pointer is over the ZERO mark.

### FRONT PANEL FUSE

The fuse at the bottom of the front panel is in series with the black test lead (jack 1). It protects both the Capacohmeter and the circuits which are tested from having too much current pass through the black test lead. When it is open, in-circuit coupling capacitor tests can not be made satisfactorily.

The fuse is mounted in an extractor-type fuseholder. To remove it for inspection or for replacement, unscrew the cover of the fuseholder and pull it out; the fuse will come out with the cover.

Replace a blown fuse with another type 3AG fuse which has a rating of 1/8 ampere only.

### PILOT LAMP

The red pilot lamp near the bottom of the front panel lights to show when power is applied to the circuits of the Capacohmeter. If it does not light when the METER ADJUST control is turned away from the OFF position and the power plug is connected to the proper type of power input, either the pilot lamp is burned out or the 1 ampere fuse inside the instrument has blown. Note that replacement of the front panel fuse will have no effect on this condition.

### OPENING THE INSTRUMENT

To open the case of the Capacohmeter and obtain access to the main circuit fuse, the tubes, and all the other com-

## MAINTENANCE

ponent parts, remove the two binder head screws through the rear of the case. These are attached to the rear of the chassis inside the instrument. Then pull forward on the edges of the front panel. The front panel and chassis will come out as a unit.

### RECTIFIERS

Each of the three basic circuits in the Capacohmeter uses a separate rectifier. CR<sub>1</sub> rectifies the voltage to be applied to the PULSE VOLTAGE control and to be used to regulate the amount of grid driving voltage for the pulse-forming thyatron tube.

Rectifier CR<sub>2</sub> makes 300 volts DC available for measuring leakage resistance in the MEGOHMS circuit.

Rectifier units CR<sub>3</sub>, CR<sub>4</sub>, CR<sub>5</sub>, and CR<sub>6</sub> together make up a full wave rectifier for changing the alternating current through the capacity measuring circuits to direct current for the meter.

If any of the rectifiers needs to be replaced, it can be identified by the lack of satisfactory operation in its own type of circuit. Replace each with an exact equivalent only.

### TUBES

Both of the tubes which are used in the Capacohmeter are in the pulse circuit. Neither of the tubes will respond satisfactorily to commercial tube tester applications. The only assured test for either tube is substitution of a known good tube in the circuit.

## MAINTENANCE

### RECALIBRATION

Whenever parts are replaced which may affect the calibration of the circuits, or whenever readings appear to be consistently in error, use the following procedures as guides for recalibration. If you do not have the proper equipment, do not attempt to recalibrate; return the Capacohmeter to the repair department at the Simpson Factory, or to your nearest official Simpson Repair Station.

Always accompany any instrument which you return for repair or recalibration with a letter to indicate what you think is wrong with it and whether you want an estimate before work begins, or if you wish to have them proceed as soon as possible. This will save both time and money for you and for the repair station or department.

### CALIBRATING CAPACITANCE RANGES

Obtain one or more known good capacitors or a capacitor decade with values between 100 micro-microfarads and 10 microfarads. The more accurate these test capacitors are, the more accuracy you will be able to establish in your Capacohmeter.

Measure the capacitance of each test capacitor on the proper range according to instructions in Section II, OPERATION.

Adjust resistor R-16 with a small screwdriver until the meter reads the correct value for each capacitor. If necessary, adjust for a compromise between the indications for all the capacitors, if you are using more than one.

## MAINTENANCE

### CALIBRATING THE PULSE CIRCUIT

The peak values for pulse voltages are marked on the PULSE VOLTAGE control at the lower left hand corner of the Capacohmeter front panel. For any setting of this control, the peak value of pulses between the red and green test leads should match the marked value at the control position.

To test pulse voltage values, it is necessary to use a calibrated oscilloscope such as the Simpson Colorscope Model 458 and observe the deflection caused by the pulses. Since most oscilloscope input circuits are rated at 500 volts maximum, it is good practice to use a 100 to 1 divider probe, Simpson Model 742, or some such similar device, between the output from the test leads and the input to the oscilloscope.

Connect the red and green test leads across the divider probe for the oscilloscope input. Set the Capacohmeter for pulse output according to the procedure in Section II, OPERATION.

### CAUTION

Do not touch the red and green test leads when the Capacohmeter is set for PULSE operation. The full value of peak voltage set on the PULSE VOLTAGE control is present between these leads.

Measure the peak value of the pulses for a setting of 500 on the PULSE VOLTAGE control. If necessary, adjust the screwdriver potentiometer, R-2, to obtain 500 volts peak as

## MAINTENANCE

indicated on the oscilloscope.

After the circuit has been calibrated for 500 volts, recheck it for 900 volts. Set the PULSE VOLTAGE control at 900 and measure the peak pulse voltage on the oscilloscope. If necessary, compromise the setting of R-2 between the indications at 500 and at 900 on the PULSE VOLTAGE control.

Be sure to turn off the pulse circuit in the Capacohmeter before you remove the test leads from the oscilloscope input.

### PARTS LIST

Reference Symbol	Description	Simpson Part No.
C-1	Capacitor, 25 $\mu$ f, 25 v dc, electrolytic	1-115818
C-2	Capacitor, 25 $\mu$ f, 25 v dc, electrolytic	1-115818
C-3	Capacitor, 0.1 $\mu$ f, 1600 v	1-115819
C-4	Capacitor, 0.25 $\mu$ f, 400 v, 10%	1-113903
C-5	Capacitor, 1 $\mu$ f, 1000 v	1-115820
C-6	Capacitor, 2000 $\mu$ f, 6 v dc, electrolytic	1-115817
C-7	Capacitor, 2000 $\mu$ f, 6 v dc, electrolytic	1-115817
CR-1	Rectifier, 20 v, 75 ma	1-115814
CR-2	Rectifier, 130 v, 75 ma (3 in series)	1-116095
CR-3	Diode, Germanium, CK706	1-115392
CR-4	Diode, Germanium, CK706	1-115392
CR-5	Diode, Germanium, CK706	1-115392
CR-6	Diode, Germanium, CK706	1-115392
F-1	Fuse, 1 ampere, type 3AG	1-112507
F-2	Fuse, 1/8 ampere, type 3AG	1-116104

## MAINTENANCE

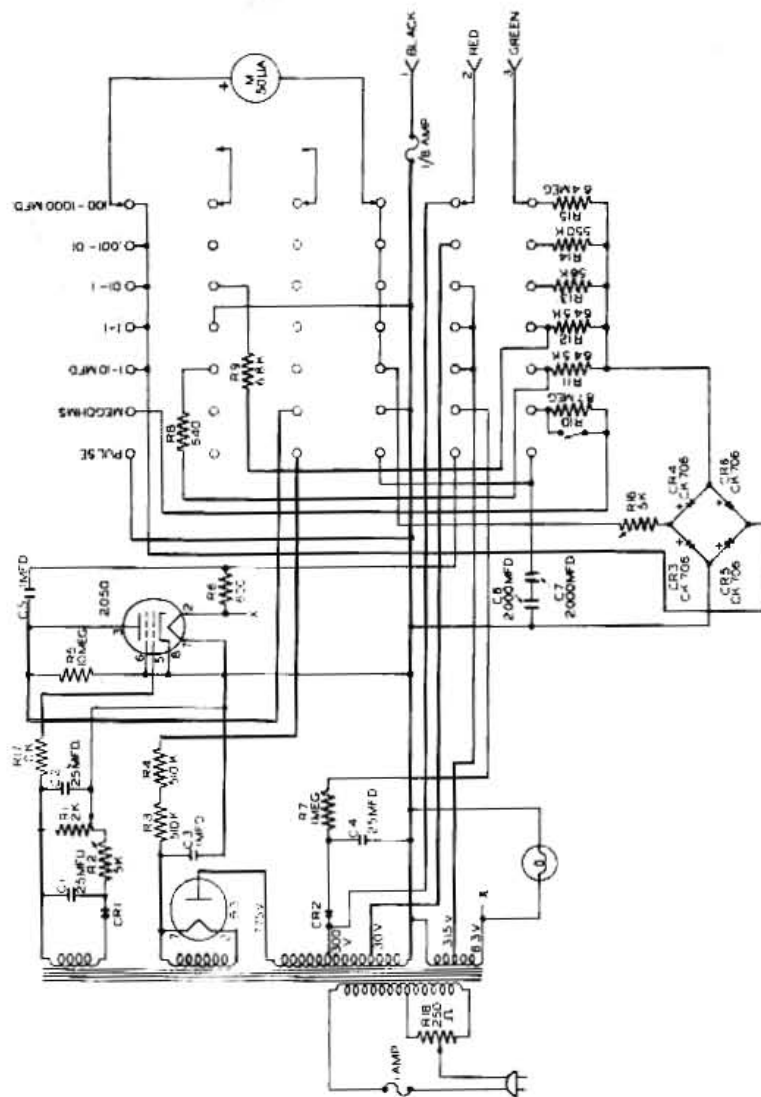

31 FIGURE 3. OVERALL SCHEMATIC DIAGRAM, SIMPSON CAPACOHMETER MODEL 383A



## MAINTENANCE

I-1	Lamp, #47	1-113747
R-1	Potentiometer, 2000 ohms, 10%	1-115809
R-2	Potentiometer, 5000 ohms, 10%	1-115808
R-3	Resistor, 510 K, ½ w, 10%	1-113951
R-4	Resistor, 510 K, ½ w, 10%	1-113951
R-5	Resistor, 10 megohms, ½ w, 10%	1-111693
R-6	Resistor, 600 ohms, 5 w, 10%	1-114759
R-7	Resistor, 1 megohm, ½ w, 1%	1-113392
R-8	Resistor, 640 ohms, ½ w, 1%	1-116102
R-9	Resistor, 6.8 K, ½ w, 1%	1-116101
R-10	Resistor, 8.7 megohms, ½ w, 1%	1-116096
R-11	Resistor, 64.5 K, ½ w, 1%	1-116100
R-12	Resistor, 64.5 K, ½ w, 1%	1-116100
R-13	Resistor, 56 K, ½ w, 1%	1-116099
R-14	Resistor, 620 K, ½ w, 1%	1-116098
R-15	Resistor, 6.4 megohms, ½ w, 1%	1-116097
R-16	Potentiometer, 5000 ohms, 10%	1-115808
R-17	Resistor, 10 K, ½ w, 10%	1-111671
R-18	Potentiometer, 250 ohms, 25 w, with OFF position	1-114722
S-1	FUNCTION switch	1-116086
S-2	METER SENS switch	1-116092
	Power transformer	1-116087
	Tube, Thyatron type 2050	1-115821
	Tube, rectifier type 1B3	1-115840
	Test lead set (3 leads)	10-837508
	Meter assembly	15-352383A
	Handle with posts	1-114024
	Knob, PULSE VOLTAGE and FUNCTION	1-115548
	Knob, METER ADJUST	1-115658

## SECTION IV

### OTHER APPLICATIONS

#### MEGOHMMETER MEASUREMENTS

The megohmmeter circuit of the Simpson Capacohmeter Model 383A may be used for many applications other than measurement of leakage resistance in capacitors. It may be used for checking the condition of any insulating material in the same way it tests the dielectric of a capacitor. It can also be used to read high-megohm values of resistance in the range from one through 1000 megohms.

For any application, use the following procedure:

1. Connect the red test lead in the red contact (jack 2) and one of the black test leads in the green contact (jack 3). Resistances will be measured between these two leads.
2. Connect the power plug into a source of 100 to 125 volts, single phase 60 cycle AC power.
3. Rotate the METER ADJUST control clockwise to turn on the instrument. The pilot lamp on the front panel should glow to indicate that power is applied to the instrument circuits.
4. Set the FUNCTION switch at MEG Ω. Connect the ends of the two test leads together to short the external circuit.
5. Rotate the METER ADJUST control to obtain a full scale deflection of the meter pointer. The instrument is now ready for use.

## OTHER APPLICATIONS

6. Separate the test leads and apply them across the resistor to be measured, or across the insulation to be rated.
7. Read the black arc of the meter for the number of megohms between the test leads.

## **PULSE TEST APPLICATIONS**

In many cases, insulation conditions will be affected differently by the application of higher voltages than they will be in the megohms measuring circuit. The insulation may be a cable or wire covering, a mounting support for a terminal, or any one of many other places where insulators are in use.

Erratic behavior of resistance when they are subjected to high voltage is another similar application for this circuit.

Do not apply the Capacohmeter leads across a transformer winding, inductance, or rectifier circuit. The output from the instrument can produce undesirable results for such connections.

To test for insulation breakdown or component stability with a high voltage, set up the Capacohmeter for pulse testing, and use it to show the condition on the GOOD and BAD portions of the meter scale. Use the following procedure:

1. Connect the red test lead in the red contact (jack 2), and connect one of the black test leads in the green contact (jack 3).
2. Connect the power plug into a source of 100 to 125 volts, single phase 60 cycle AC power.

## OTHER APPLICATIONS

3. Set the FUNCTION switch at MEG  $\Omega$ , or in any capacity range position.
4. Rotate the METER ADJUST control to turn on the Capacohmeter. The pilot lamp on the front panel should light to indicate when power is applied to the instrument circuits.
5. After a short warm-up period, short the ends of the two test leads together. The meter should read full scale. Set the METER ADJUST control for exactly full scale on the meter.
6. Separate the test leads and connect them across the insulation or component which is to be tested.
7. Rotate the PULSE VOLTAGE control fully counter-clockwise, to its lowest setting.
8. Set the FUNCTION switch at PULSE.

### CAUTION

Do not touch the test leads while the FUNCTION switch is in the PULSE position. High voltage pulses are present between the ends of the test leads.

9. Advance the PULSE VOLTAGE control to apply whatever peak value of voltage you need to test the insulator or component. The limit is 900 volts.
10. Observe the inner arc of the meter during the pulse voltage application. It shows GOOD AND BAD.
11. Always turn the FUNCTION switch to a position other than PULSE before you handle the test leads, or move them to a new location.

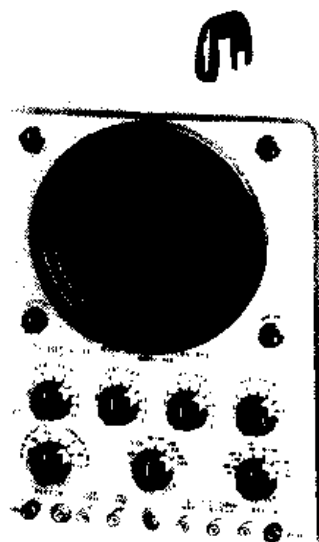

Simpson

# 7" COLORSCOPE

## MODEL 458

Seven big features make Model 458 the ideal scope for color TV servicing: (1) 7" Cathode Ray Tube; (2) On wide band operation, the frequency response is flat within 1.5 db to 4.5 Mc. Will faithfully display COLOR BURST frequency with a sensitivity greater than 30 Mv rms per inch of vertical deflection; (3) On narrow band operation, the frequency response is flat within 3 db from 10 cycles to 300 Kc with a sensitivity greater than 10 Mv rms per inch; (4) Good square wave response provides accurate representation of sync pulses and composite wave-form pattern for trouble-shooting video, sync, and sweep circuits; (5) Horizontal Sweep, to 200 Kc, for expansion of high frequency wave-form detail and color burst; (6) Vernier and Compensated Decimal Step Attenuator for better signal controls and (7) Provision for Intensity Modulation of CRT.

**Size:** 11 x 16½ x 14½ High. **Weight:** 29 lbs.

### WARRANTY

SIMPSON ELECTRIC COMPANY warrants each instrument and other articles of equipment manufactured by it to be free from defects in material and workmanship under normal use and service, its obligation under this warranty being limited to making good at its factory any instrument or other article of equipment which shall within 90 days after delivery of such instrument or other article of equipment to the original purchaser be returned intact to it, or to one of its authorized service stations, with transportation charges prepaid, and which its examination shall disclose to its satisfaction to have been thus defective; this warranty being expressly in lieu of all other warranties expressed or implied and of all other obligations or liabilities on its part, and SIMPSON ELECTRIC COMPANY neither assumes nor authorizes any other persons to assume for it any other liability in connection with the sale of its products.

This warranty shall not apply to any instrument or other article of equipment which shall have been repaired or altered outside the SIMPSON ELECTRIC COMPANY factory or authorized service stations, nor which has been subject to misuse, negligence or accident, incorrect wiring by others, or installation or use not in accord with instructions furnished by the manufacturer.

## Simpson ELECTRIC COMPANY

5200 Kinzie St., Chicago 44, Illinois • Phone: EStebrook 9-1121

In Canada: Bach-Simpson, Ltd., London, Ontario



LAC DU FLAMBEAU PLANT  
WISCONSIN



LAKE STREET PLANT  
CHICAGO



KINZIE STREET PLANT  
CHICAGO



AURORA PLANT  
AURORA, ILL.

# **WARNING!**

**DO NOT ATTEMPT TO OPERATE THIS TESTER BEFORE COMPLETELY READING THIS MANUAL. FAILURE TO DO SO, COULD RESULT IN INCORRECT USAGE AND PRESENT THE POSSIBILITY OF SEVERE SHOCK OR EQUIPMENT DAMAGE.**

**HIGH AC AND PULSED VOLTAGES ARE PRESENT ACROSS THE TEST LEADS DURING SOME APPLICATIONS. DO NOT SHORT LEADS ACCIDENTALLY OR CONTACT WITH FINGERS. TEST LEADS WHICH ARE NOT USED FOR SOME CHECKS SHOULD BE DISCONNECTED FROM THE CAPACOHMETER.**